

Project: Multiple Projects

Country: Germany

Scope of Work: Various Steel Staircases:

- Structural Analysis
- 3D Modeling
- Erection and Fabrication Drawings

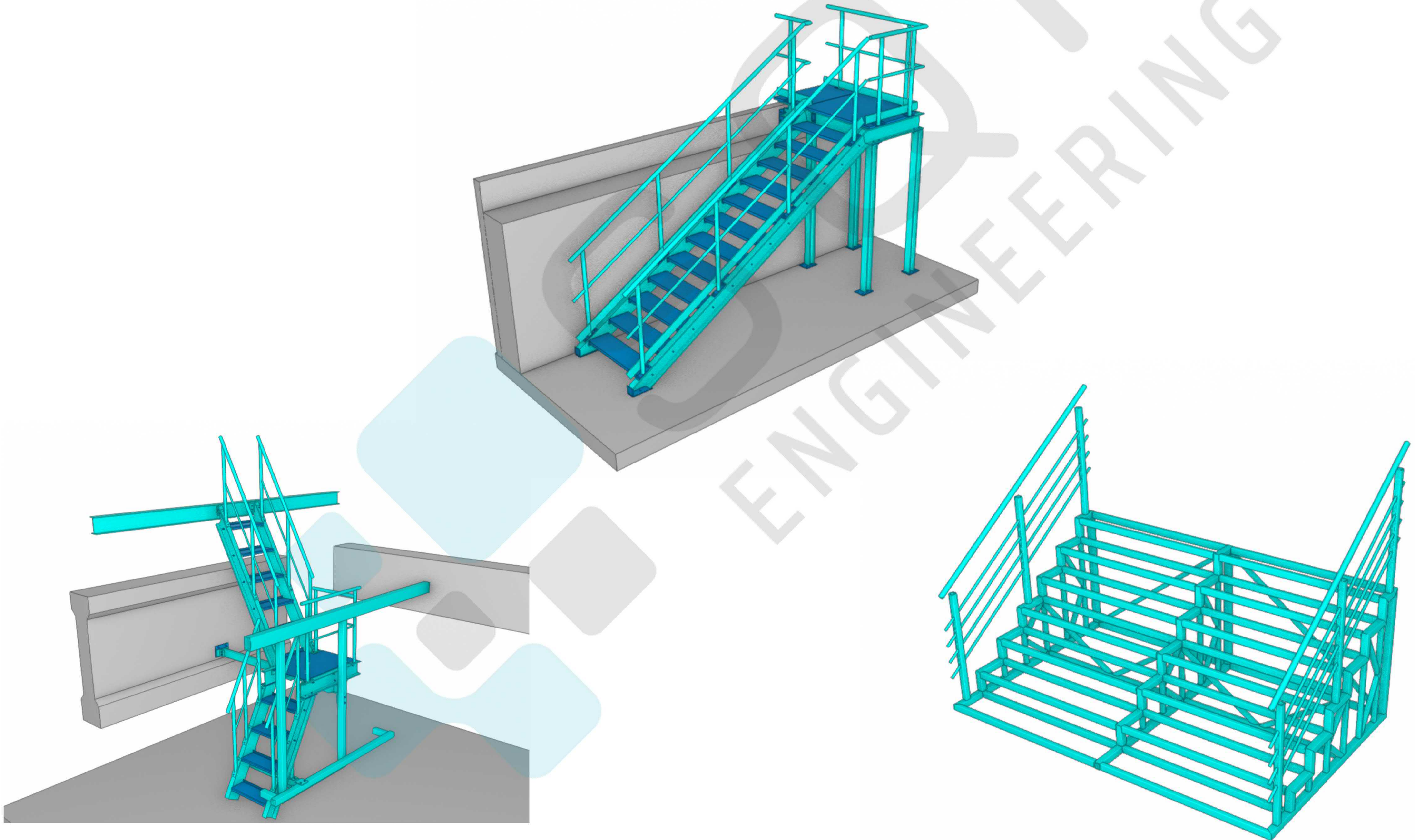

Structural Analysis

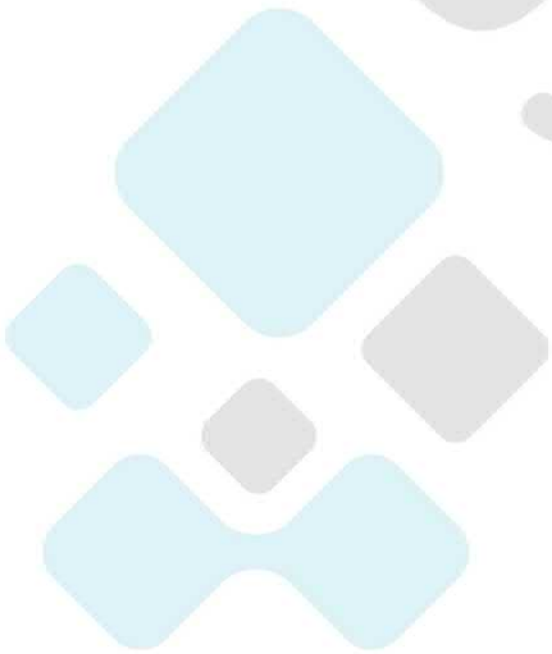

SSQR
ENGINEERING

6.2.1 **MODELL**

LF3 - Nutzlast
Lasten [kN/m²]

In axonometrischer Richtung

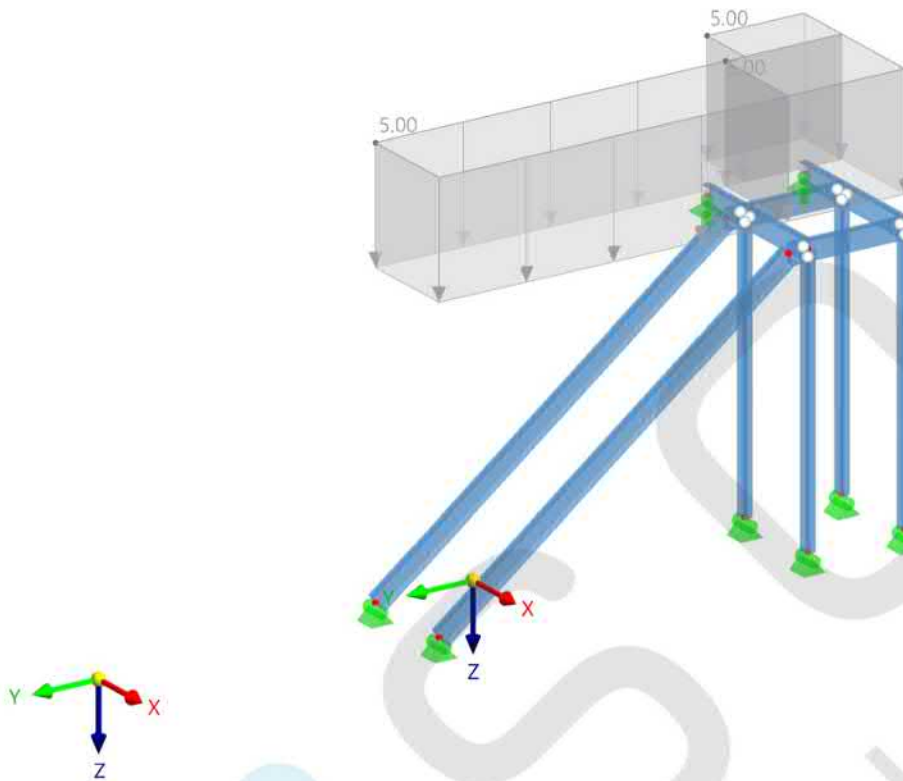

6.3.1

STABLASTEN

LF4: Temperaturlast + QT

Last Nr.	Stäbe Nr.	Last-Typ	Last-Verteilung	Koord.-System	Last-Richtung	Symbol	Parameter Wert	Einheit
1	1-6,11,13,15-20	■ Temperaturänderung	■ Konstant	Lokales Koordinatensystem xyz	y	T_c	57.0	°C
						ΔT	0.0	°C

6.3.2 **MODELL**

LF4 - Temperaturlast +
Lasten [°C]

In axonometrischer Richtung

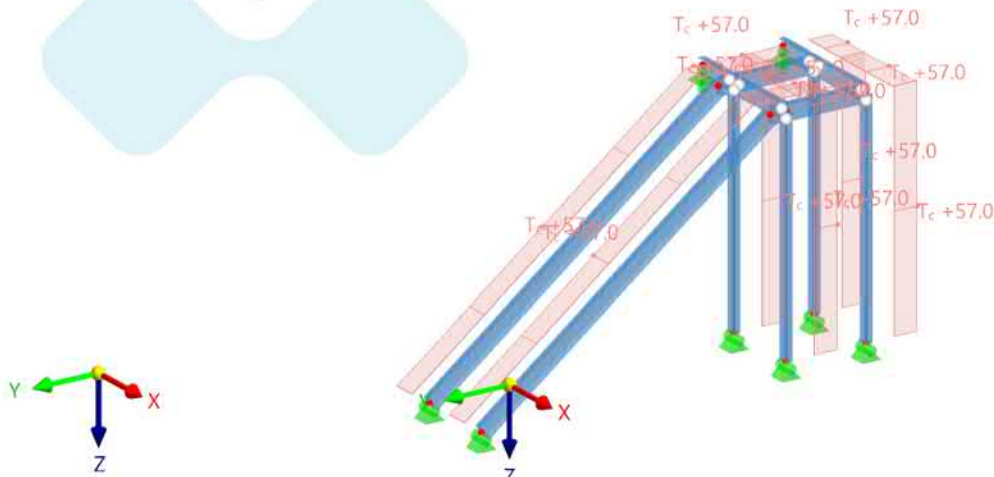

LK2 - 1.35 * LF1 + 1.35 * LF2 + 1.50 * LF3
 Statische Analyse
 Momente M_y [kNm]

In axonometrischer Richtung

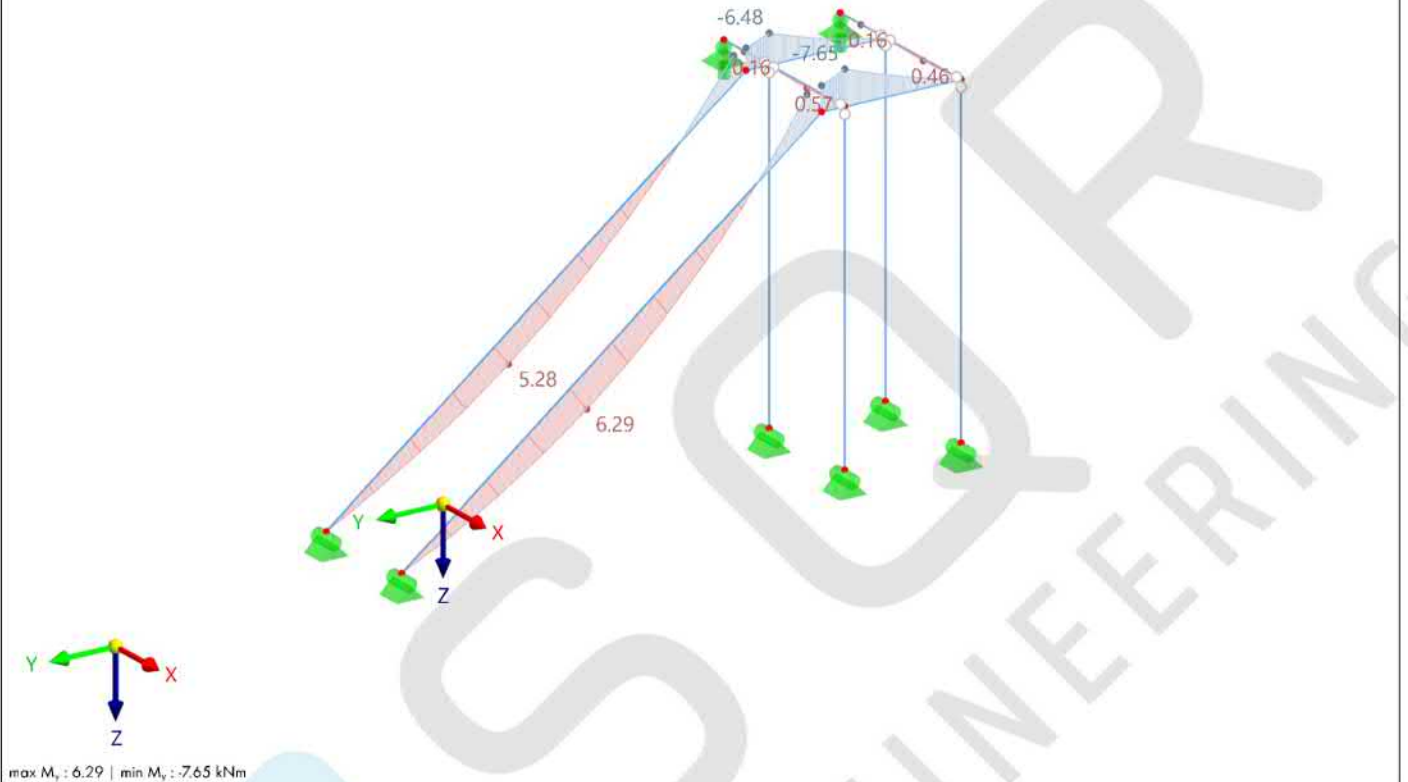

LK2 - 1.35 * LF1 + 1.35 * LF2 + 1.50 * LF3
 Statische Analyse
 Kräfte V_z [kN]

In axonometrischer Richtung

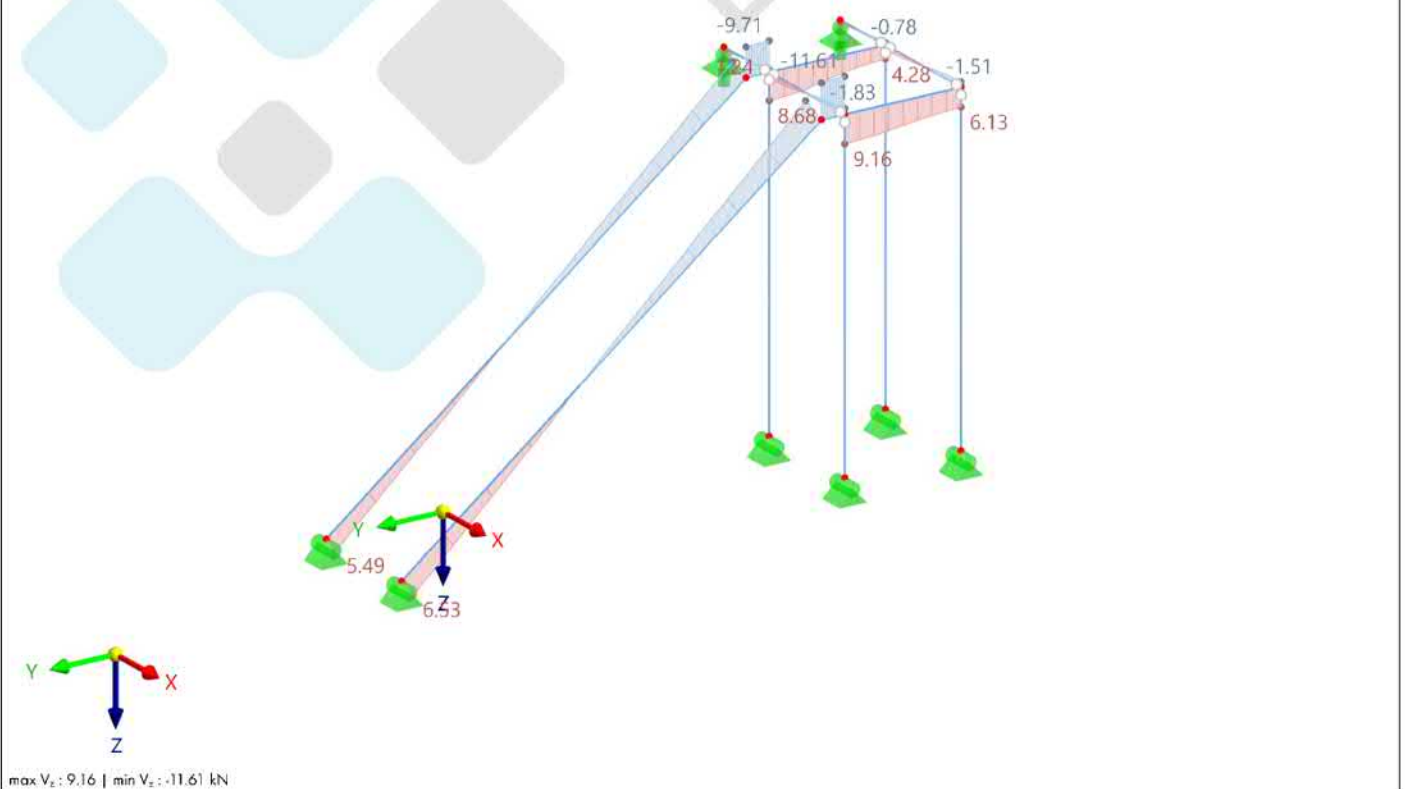

1 Basisobjekte

1.1 MATERIALIEN

Material Nr.	Name des Materials	Material-Typ	Analyse Modell
1	S235JR Isotrop Linear elastisch	Stahl	Isotrop Linear elastisch

1.2 QUERSCHNITTE

MSH QHP 40x4



MSH RHP 60x40x4



Quersch. Nr.	Material Nr.	Querschnitts-Typ	Herstellungs-Typ	I_x [cm ⁴] A [cm ²]	I_y [cm ⁴] A _y [cm ²]	I_z [cm ⁴] A _z [cm ²]	Gesamtabmessungen b [mm] h [mm]	
1	1	MSH QHP 40x4 1 - S235JR Genormt - Stahl	Warmgewalzt	19.50	11.80	11.80	40.0	40.0
				5.59	2.56	2.56		
2	1	MSH RHP 60x40x4 1 - S235JR Genormt - Stahl	Warmgewalzt	36.70	32.80	17.00	40.0	60.0
				7.19	2.22	4.26		
3	1	MSH QHP 60x4 1 - S235JR Genormt - Stahl	Warmgewalzt	72.50	45.40	45.40	60.0	60.0
				8.79	3.91	3.91		

MSH QHP 60x4



1.3 MODELL

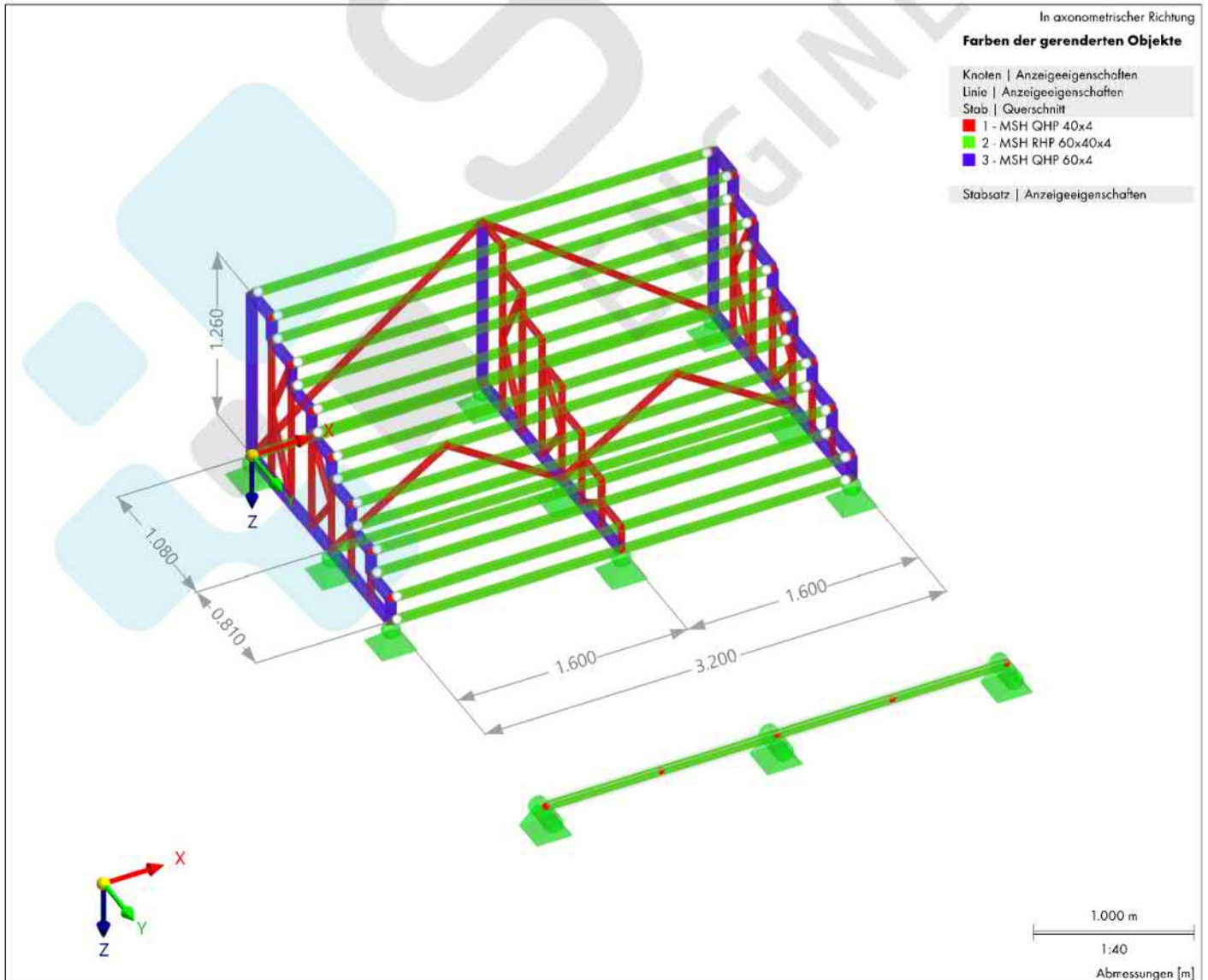

9.3 **MODELL**

Statische Analyse

Sichtbarkeitsmodus
 EK1 - 1.35 * LF1/ρ + 1.35 * LF2/ρ + 1.50 * LF3
 Statische Analyse
 Kräfte V_z [kN]

In axonometrischer Richtung

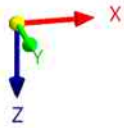
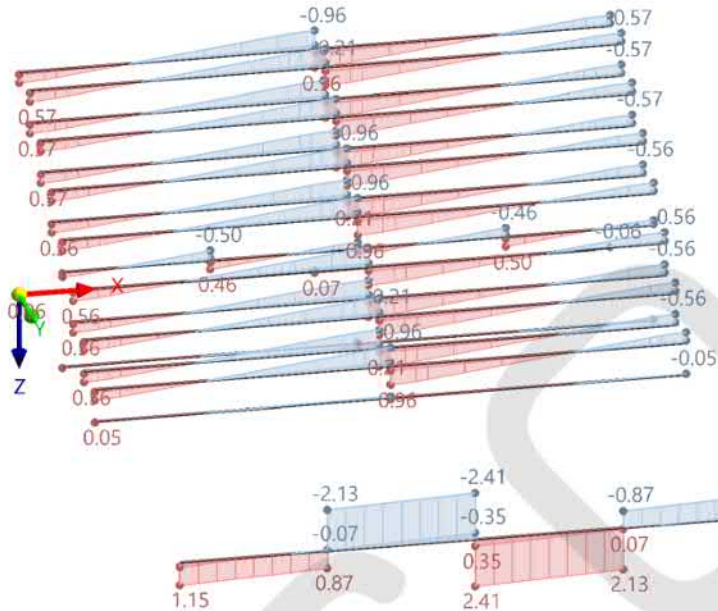

max V_z : 2.41 | min V_z : -2.41 kN

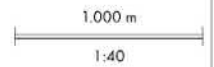

9.4 **MODELL**

Statische Analyse

Sichtbarkeitsmodus
 EK2 - 1F1/ρ + 1F2/ρ + 1F3
 Statische Analyse
 Verschiebungen u_z [mm]

In axonometrischer Richtung

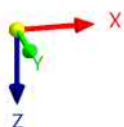
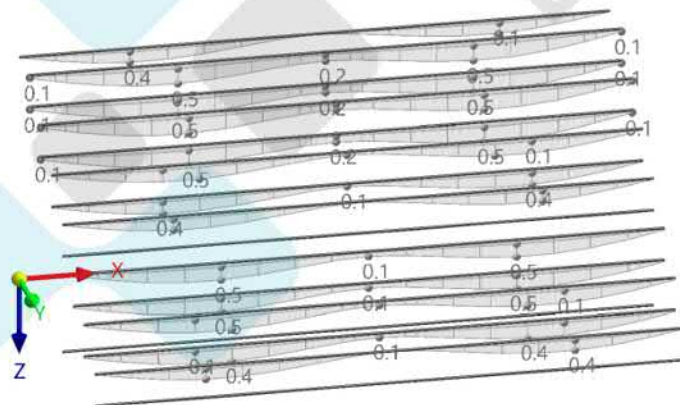

max u_z : 1.3 | min u_z : 0.0 mm

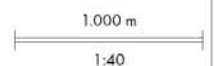

Material

Stahl S 235

Projektposition CON1

Bemessung

Name CON1
 Beschreibung
 Berechnung Spannung, Dehnung/ Vereinfachte Belastung

Bauteile

Geometrie

Name	Querschnitt	β - Rotation [°]	Y - Rotation [°]	α - Rotation [°]	Abstand ex [mm]	Abstand ey [mm]	Abstand ez [mm]
C	4 - SHS60/60/6.3	0,0	0,0	0,0	0	0	0
M2	5 - SHS50/50/4.0	0,0	90,0	0,0	0	0	0

Auflager und Kräfte

Name	Auflager	Kräfte in	X [mm]
C / anfang	N-Vy-Vz-Mx-My-Mz	Schrauben	0
C / ende	N-Vy-Vz-Mx-My-Mz	Schrauben	0
M2 / ende		Schrauben	0

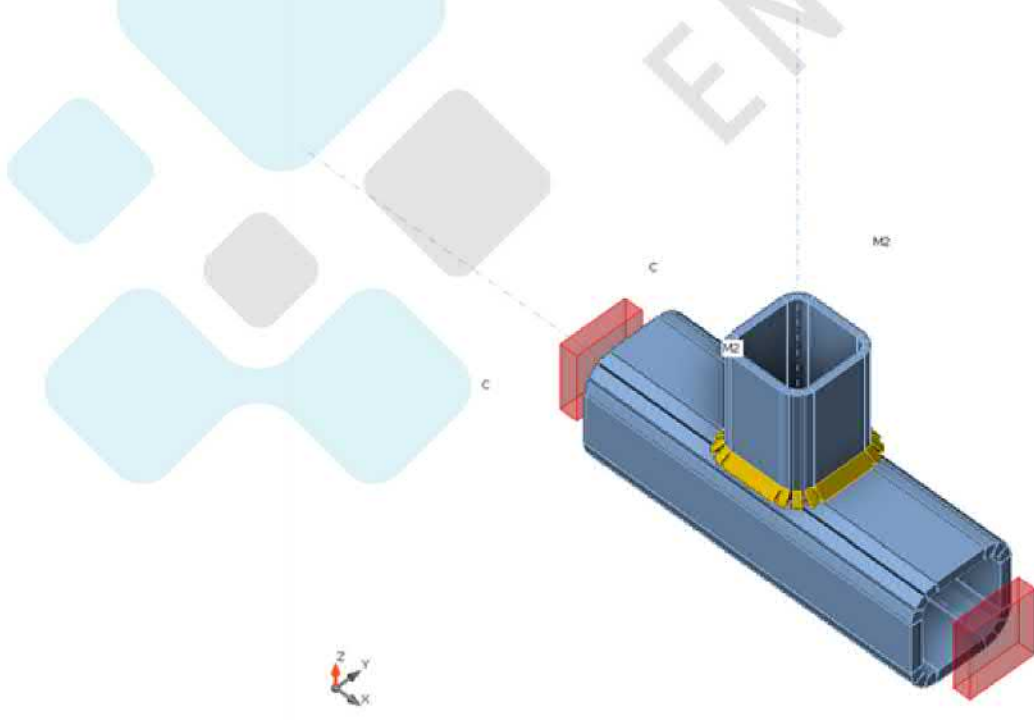

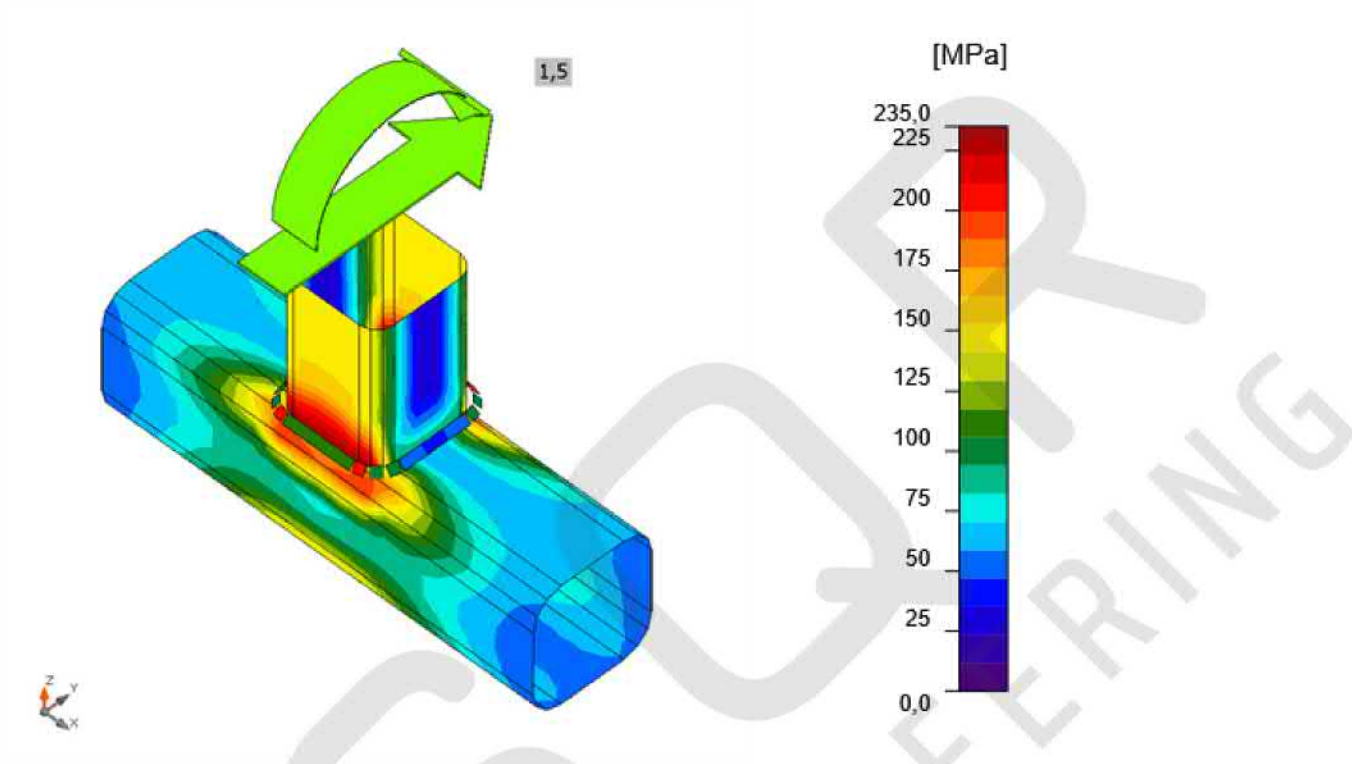

Vergleichsspannung, LE1

Schweißnähte

Position	Kante	T_w [mm]	L [mm]	Lasten	$\sigma_{w,Ed}$ [MPa]	ϵ_{pl} [%]	σ_{\perp} [MPa]	τ_{\perp} [MPa]	τ_{\parallel} [MPa]	Ut [%]	Ut _c [%]	Status
C-w 3	M2	▲ 4,0 ▼	168	LE1	203,3	0,0	-44,7	-114,5	-0,8	56,5	32,9	OK
		▲ 4,0 ▼	169	LE1	203,7	0,0	145,0	-74,9	34,9	56,6	32,5	OK

Bemessungsdaten

Material	f_u [MPa]	β_w [-]	$\sigma_{w,Rd}$ [MPa]	$0,9 \sigma$ [MPa]
S 235	360,0	0,80	360,0	259,2

Structural Drawings

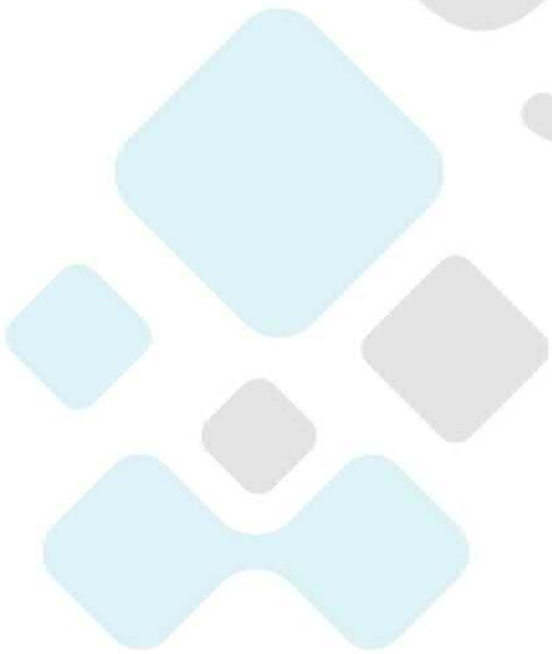

SSQR
ENGINEERING

4x (1051) BL10x60x200
S235JR - 1:10

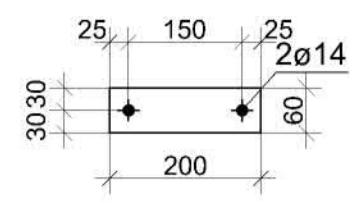

2x (1052) BL10x100x176
S235JR - 1:10

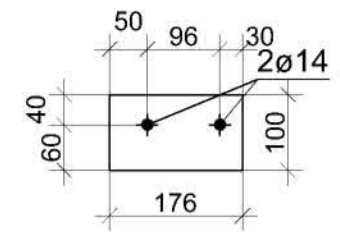

2x (1053) BL10x100x176
S235JR - 1:10

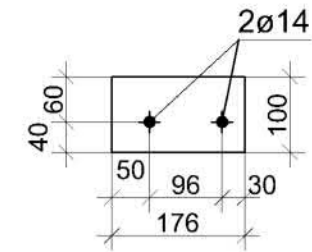

2x (1054) BL10x100x256
S235JR - 1:10

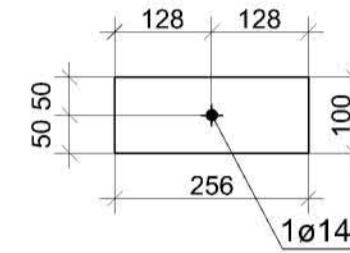

2x (1055) BL10x140x140
S235JR - 1:10

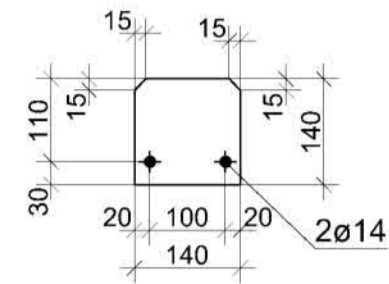

2x (1056) BL10x175x200
S235JR - 1:10

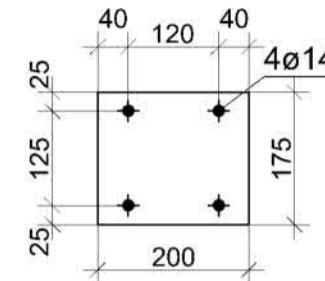

2x (1057) BL10x90x100
S235JR - 1:10

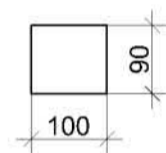

2x (1058) BL10x60x150
S235JR - 1:10

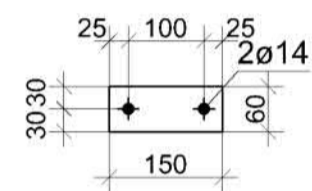

2x (1059) BL10x60x80
S235JR - 1:10

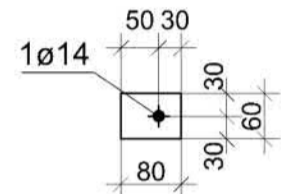

12x (1060) Gitterroststufe 30/30 rh - 1000x270mm
S235JR - 1:10

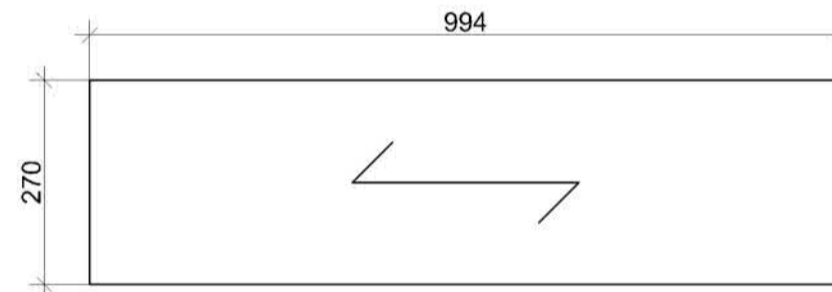

1x (1061) Gitterrost 30/30 rh - 1000x600mm
S235JR - 1:10

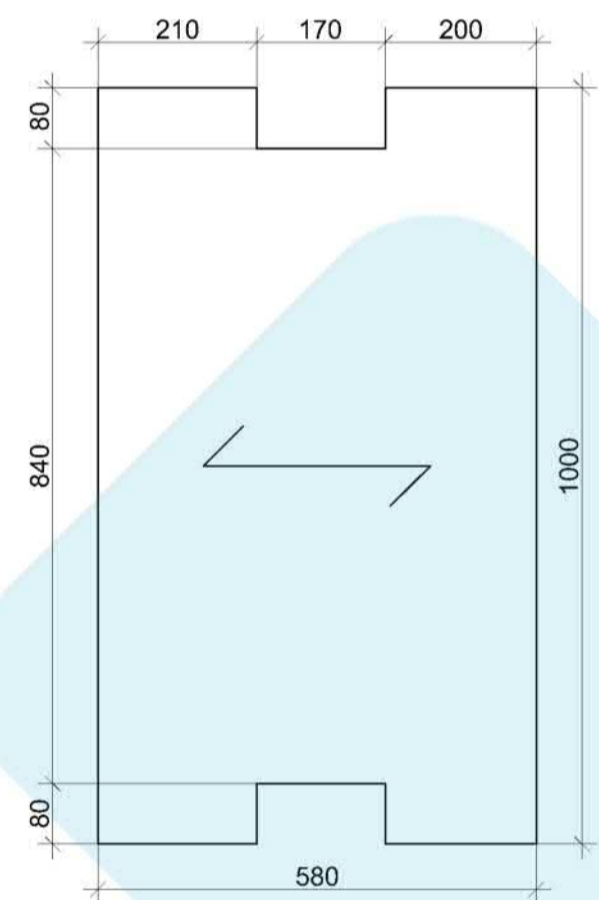

1x (1062) Gitterrost 30/30 rh - 1000x1200mm
S235JR - 1:10

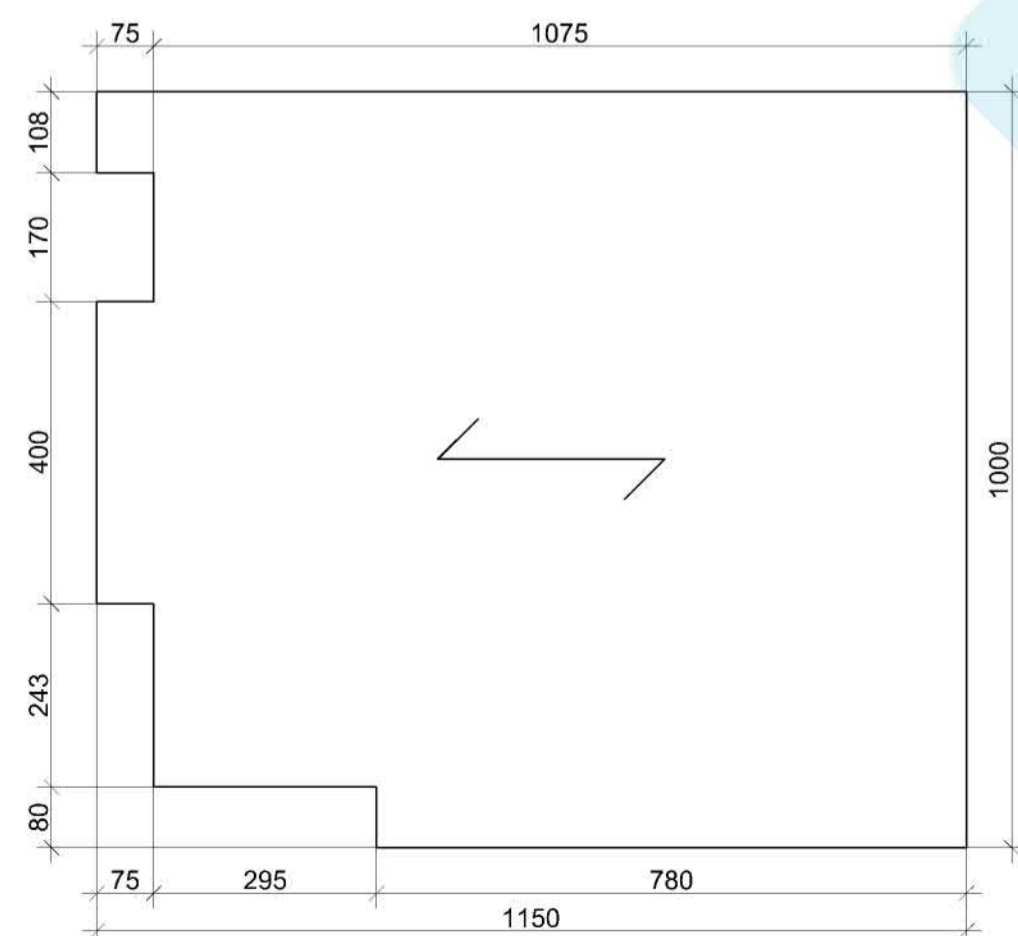

Pos.	Stk.	Bezeichnung	Länge	Material	Einzelgewicht	Gesamtgewicht
1000	6	FL100X10	1292	S235JR	10.14	60.84
1001	4	HEA100	2015	S235JR	33.65	134.6
1002	4	RO48.3X4	1092	S235JR	4.77	19.09
1003	4	RO48.3X4	1092	S235JR	4.77	19.09
1004	3	FL100X10	231	S235JR	1.81	5.43
1005	3	RO33.7X4	1197	S235JR	3.51	10.52
1006	3	RO33.7X4	1197	S235JR	3.51	10.52
1007	3	RO48.3X4	1071	S235JR	4.68	14.04
1008	2	FL100X10	280	S235JR	2.2	4.4
1009	2	RO33.7X4	183	S235JR	0.54	1.08
1010	2	RO33.7X4	263	S235JR	0.77	1.54
1011	2	RO48.3X4	1071	S235JR	4.68	9.36
1012	1	FL100X10	1170	S235JR	9.18	9.18
1013	1	FL100X10	570	S235JR	4.47	4.47
1014	1	FL100X10	374	S235JR	2.94	2.94
1015	1	FL100X10	226	S235JR	1.77	1.77
1016	1	FL100X10	209	S235JR	1.64	1.64
1017	1	FL100X10	200	S235JR	1.57	1.57
1018	1	FL100X10	173	S235JR	1.36	1.36
1019	1	FL100X10	168	S235JR	1.32	1.32
1020	1	L50X6	210	S235JR	0.94	0.94
1021	1	L50X6	210	S235JR	0.94	0.94
1022	1	RO33.7X4	536	S235JR	1.57	1.57
1023	1	RO33.7X4	197	S235JR	0.58	0.58
1024	1	RO33.7X4	183	S235JR	0.54	0.54
1025	1	RO33.7X4	1136	S235JR	3.33	3.33
1026	1	RO33.7X4	340	S235JR	1	1
1027	1	RO33.7X4	250	S235JR	0.73	0.73
1028	1	RO33.7X4	188	S235JR	0.55	0.55
1029	1	RO33.7X4	183	S235JR	0.54	0.54
1030	1	RO33.7X4	111	S235JR	0.33	0.33
1031	1	RO48.3X4	4098	S235JR	17.91	17.91
1032	1	RO48.3X4	4091	S235JR	17.88	17.88
1033	1	RO48.3X4	1724	S235JR	7.53	7.53
1034	1	RO48.3X4	992	S235JR	4.33	4.33
1035	1	RO48.3X4	644	S235JR	2.81	2.81
1036	1	RO48.3X4	121	S235JR	0.53	0.53
1037	1	UPE200	4138	S235JR	94.35	94.35
1038	1	UPE200	4138	S235JR	94.35	94.35
1039	1	UPE200	1049	S235JR	23.92	23.92
1040	1	UPE200	1049	S235JR	23.92	23.92
1041	1	UPE200	980	S235JR	22.34	22.34
1042	1	UPE200	980	S235JR	22.34	22.34
1043	1	UPE200	445	S235JR	10.15	10.15
1044	1	UPE200	445	S235JR	10.15	10.15
1045	24	BL3x70x270	270	S235JR	0.43	10.43
1046	4	BL10x150x200	200	S235JR	2.35	9.4
1047	2	BL10x80x150	150	S235JR	0.94	1.88
1048	4	BL10x70x140	140	S235JR	0.75	3.01
1049	3	BL10x60x150	150	S235JR	0.71	2.13
1050	4	BL10x60x200	200	S235JR	0.75	3.01
1051	4	BL10x60x200	200	S235JR	0.75	3.01
1052	2	BL10x100x176	176	S235JR	1.38	2.76
1053	2	BL10x100x176	176	S235JR	1.38	2.76
1054	2	BL10x100x256	256	S235JR	2.01	4.03
1055	2	BL10x140x140	140	S235JR	1.52	3.04
1056	2	BL10x175x200	200	S235JR	2.75	5.49
1057	2	BL10x90x100	100	S235JR	0.71	1.41
1058	2	BL10x60x150	150	S235JR	0.71	1.42
1059	2	BL10x60x80	80	S235JR	0.38	0.76
1060	12	Gitterroststufe	994	S235JR	7.25	86.96
1061	1	Gitterrost	580	S235JR	8.18	8.18
1062	1	Gitterrost	1150	S235JR	15.84	15.84
					Gesamt	844.60

- Allgemeine Hinweise**
- Berechnung nach DIN EN 1993-1-1: Allgemeine Bemessungsregeln und Regeln für den Hochbau und DIN EN 1993-1-8: Bemessung und Konstruktion von Anschlüssen
 - Ausführung nach DIN EN 1090-1 und -2:
 - Herstellungskategorie: PC1 (Stahlorte unter S235)
 - Schadensfolgenklassen: CC2 (Mittlere Folgen für Menschenleben)
 - Ausführungskategorie: EXC2.
 - Stahlorte für alle Stahlbauteile ist S235 nach DIN EN 10025.
 - Schweißverbindungen nach DIN EN ISO 5817- Bewertungsguppe C.
 - Alle Kehlnähte, die auf dem Plan nicht eingezeichnet sind, sind $a = \min. \sqrt[4]{(max\ t) \cdot 0.5}$ und $> 3mm$ umlaufend vorzusehen. Davon sind die Hohlprofile ausgenommen, bei denen gilt: $a > 0.92t$.
 - Geschraubte Verbindungen sind mit Schraubenfestigkeitsklasse 8.8 vorzusehen, außer wenn es im Detail nicht anderes angegeben ist.
 - Schraubengarnitur ist nach DIN EN ISO 4014, DIN EN ISO 4032 und DIN EN ISO 7091 zu wählen.
 - Alle Hohlprofile mit Stahlblech $d=3mm$ schließen.
 - Antikorrosionsschutz: Alle Stahlteile sind nach DIN EN ISO 1461 feuerverzinkt. Ausführung und Vorbereitung der Bauteile gemäß DIN EN ISO 14713-2.

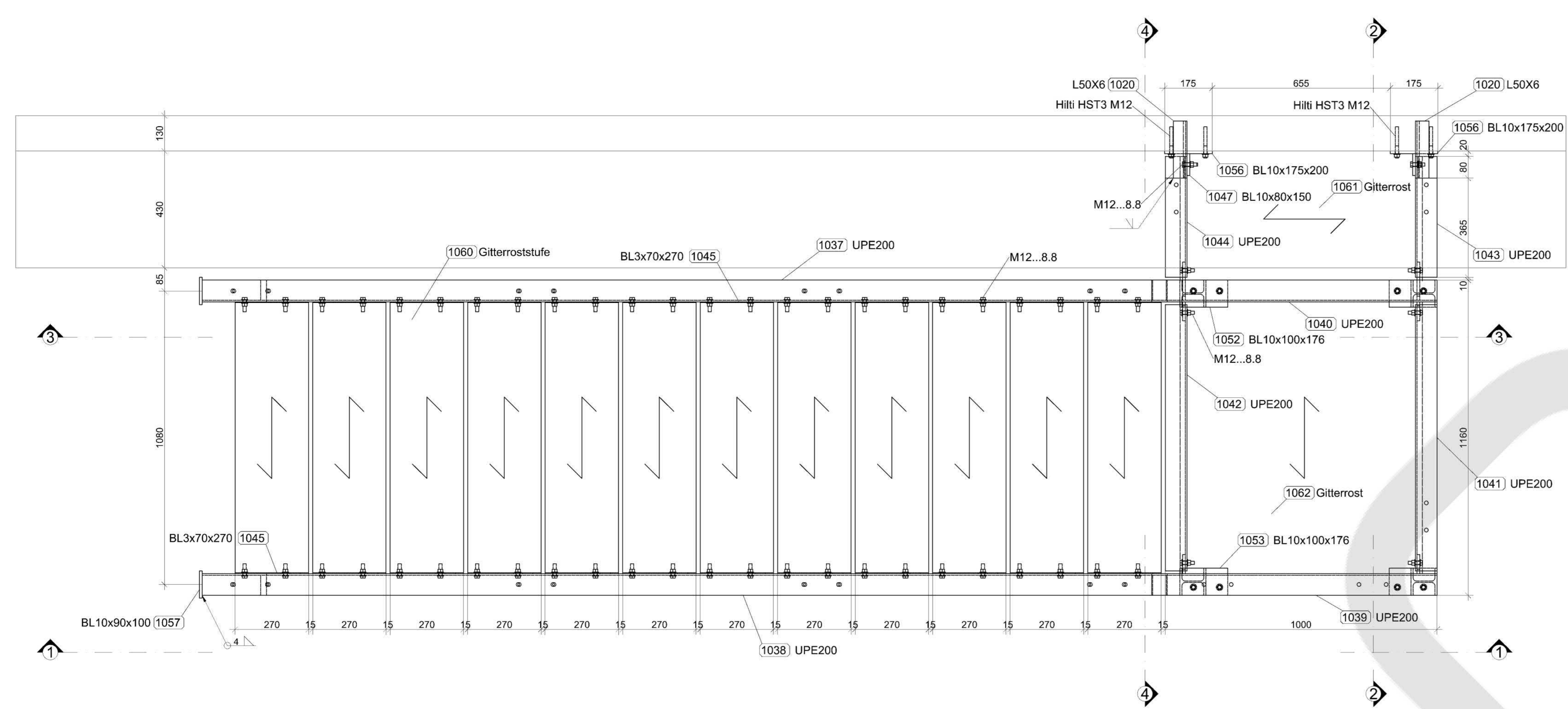

Schnitt 1-1

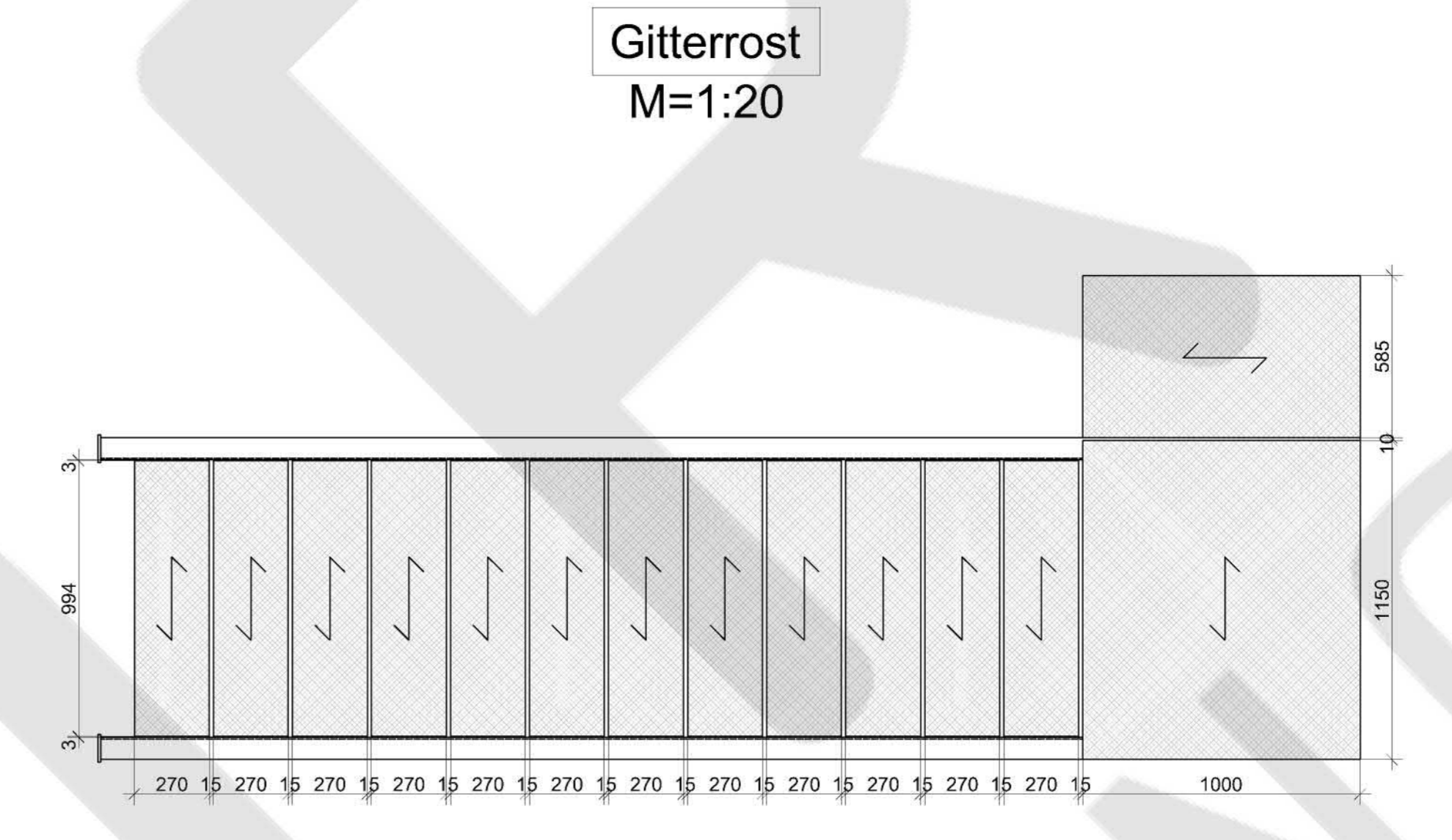

Schnitt 2-2

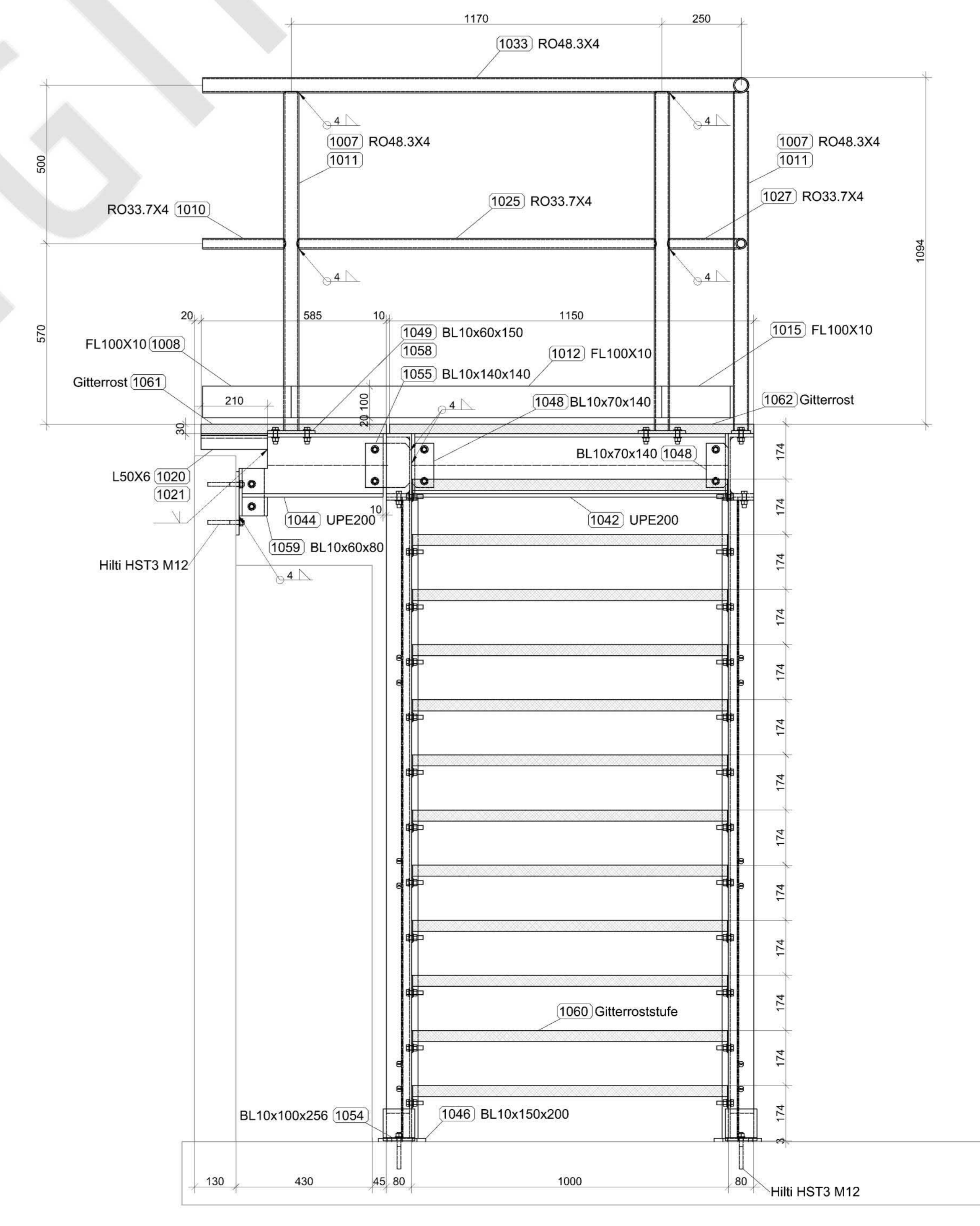
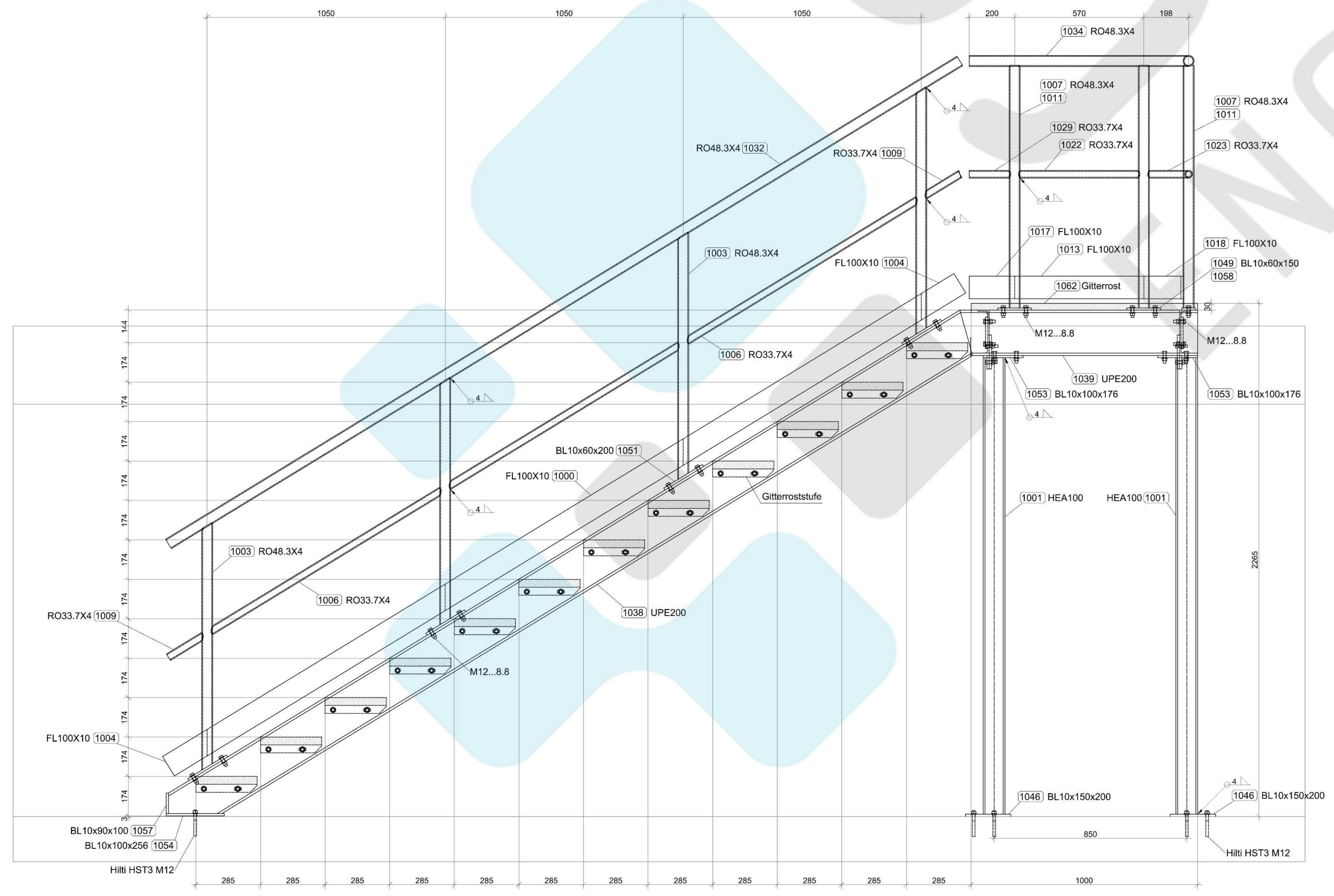

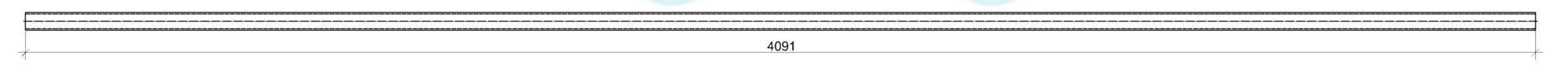
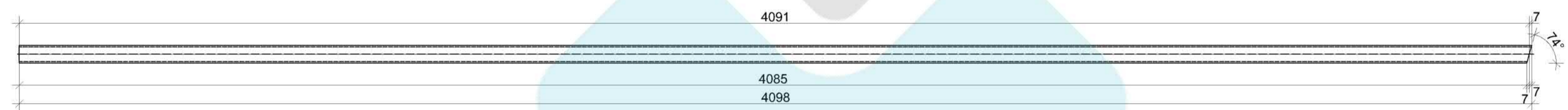
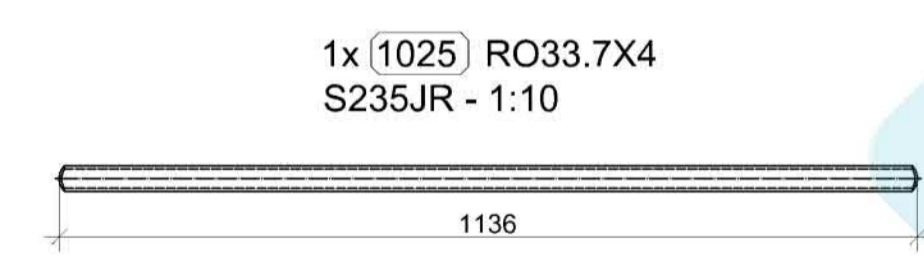
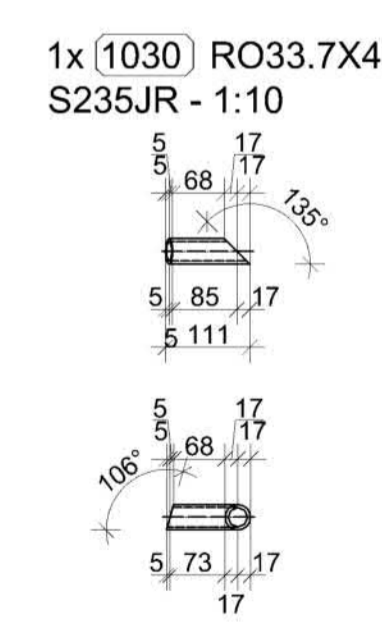
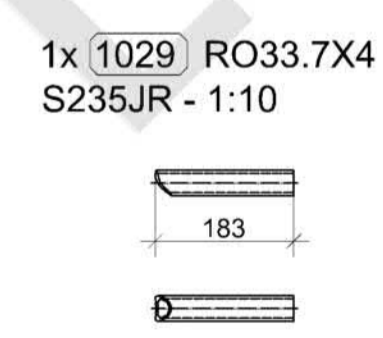
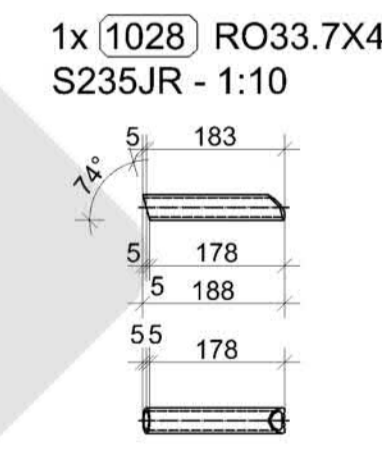
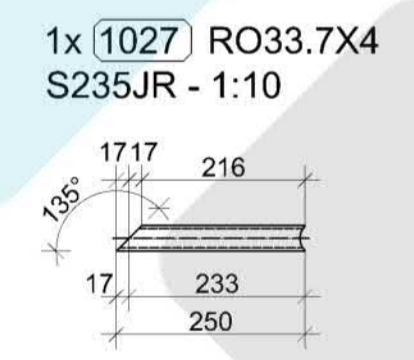
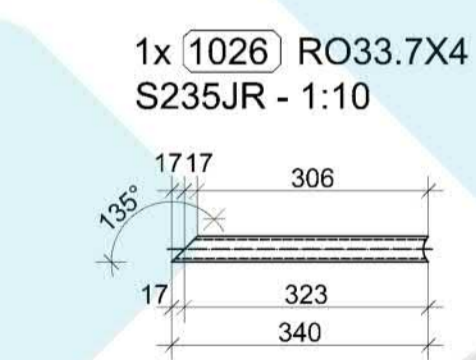
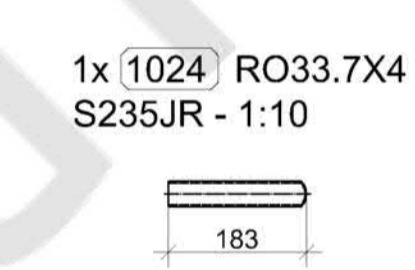
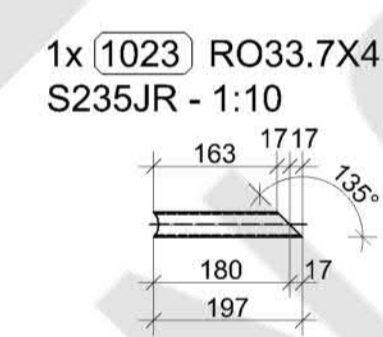
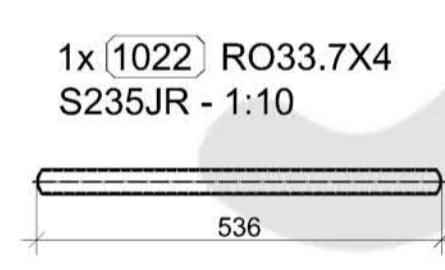
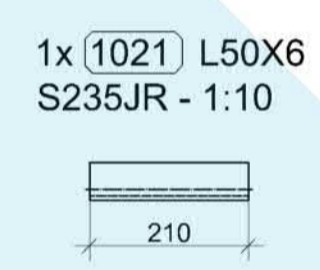
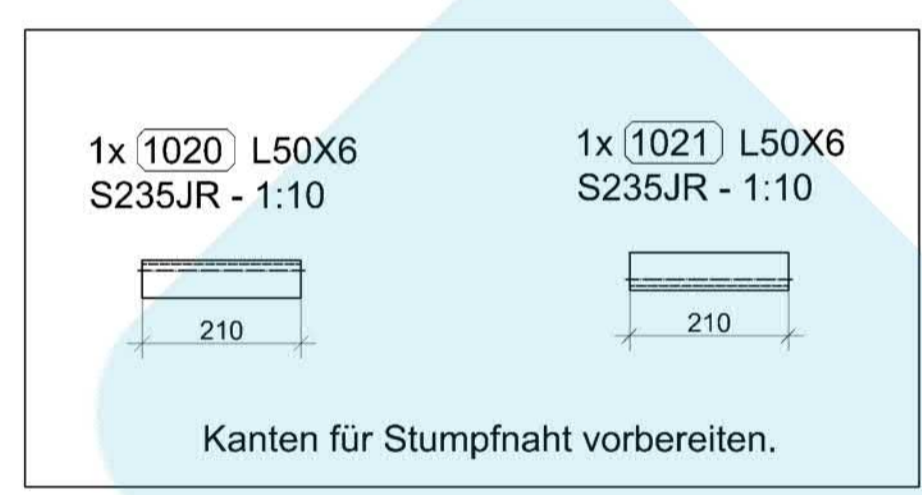
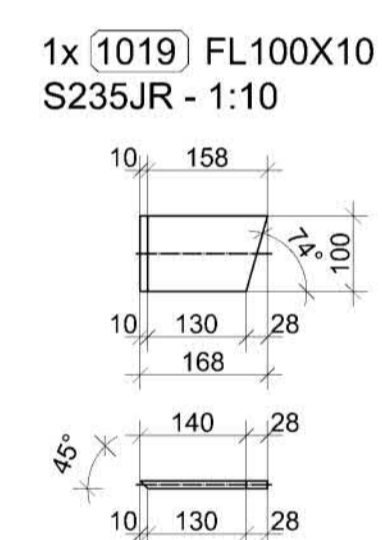
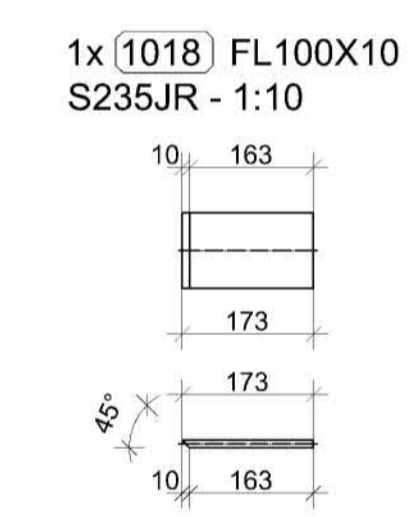
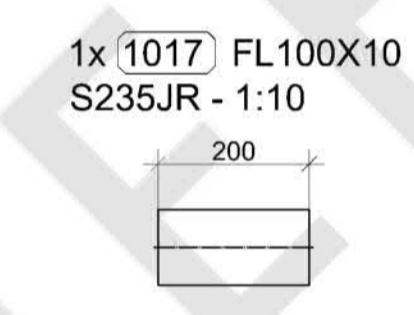
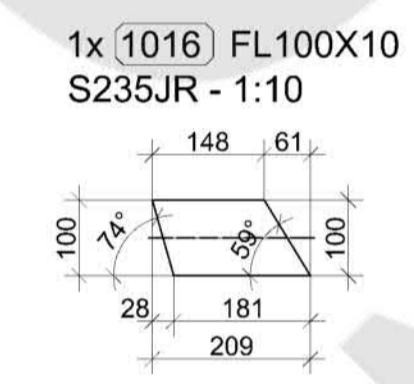
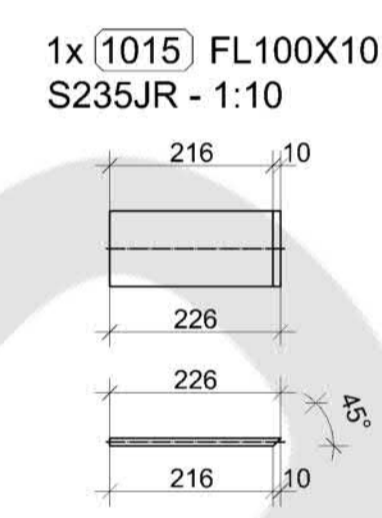
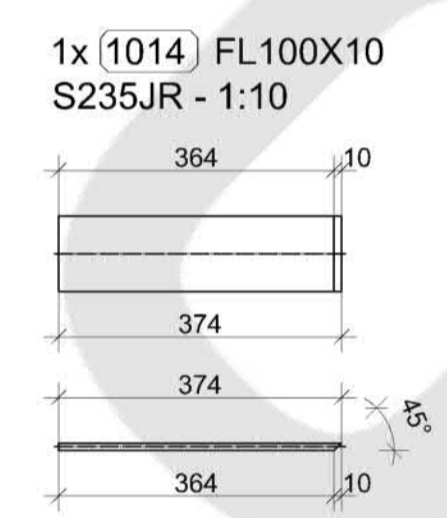
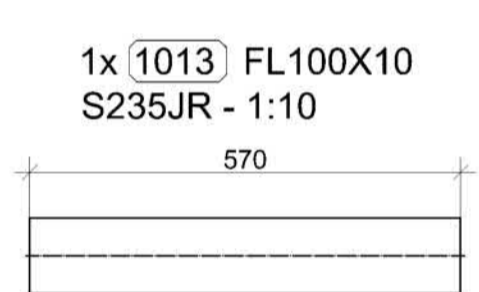
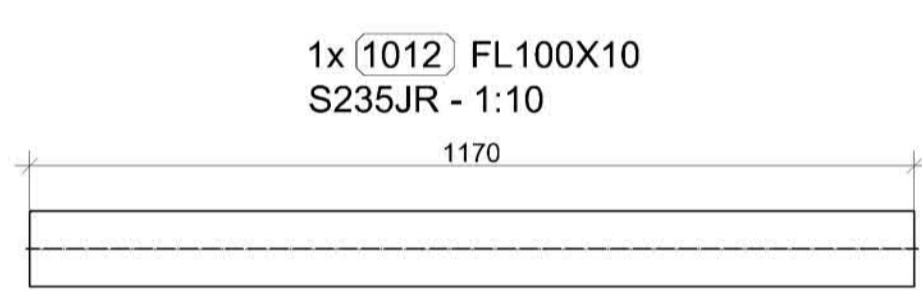
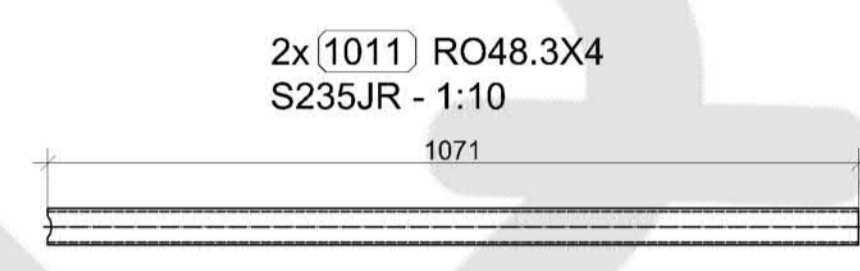
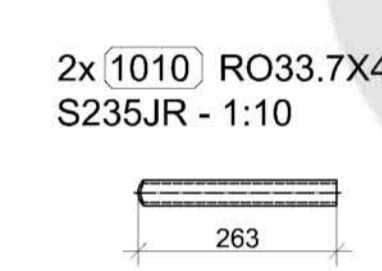
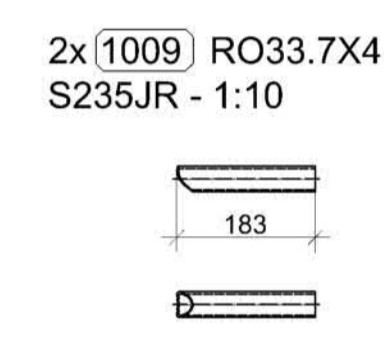
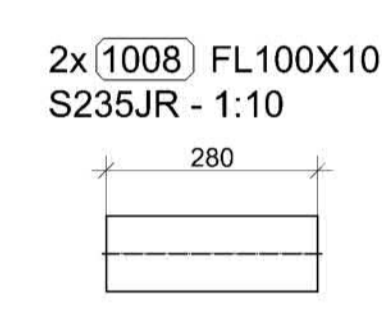
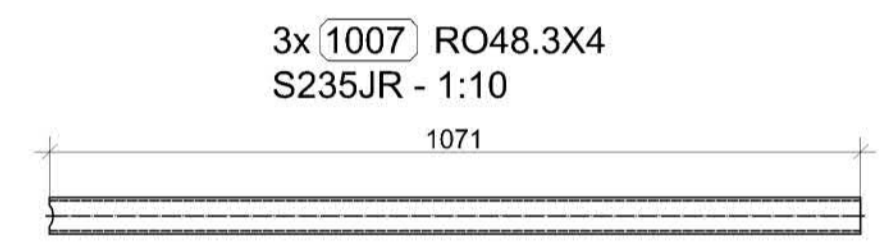
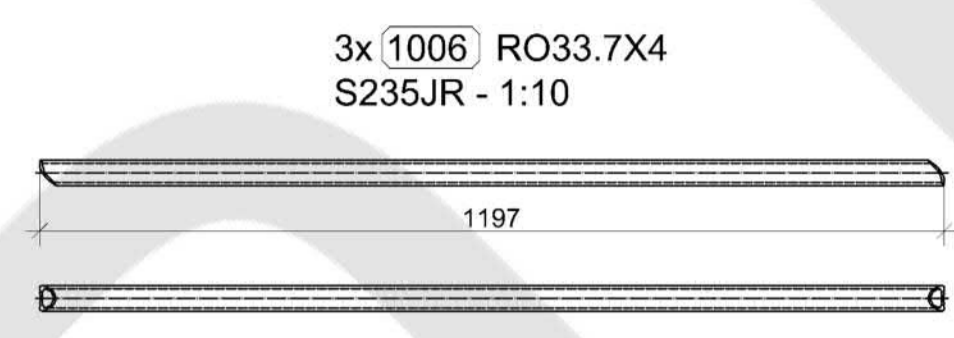
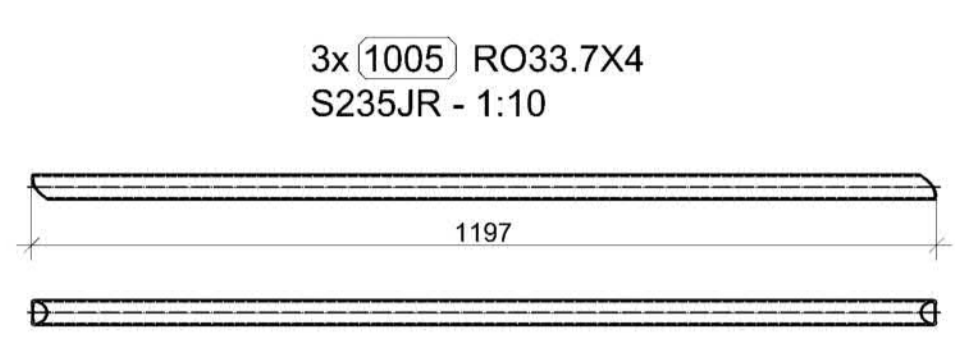
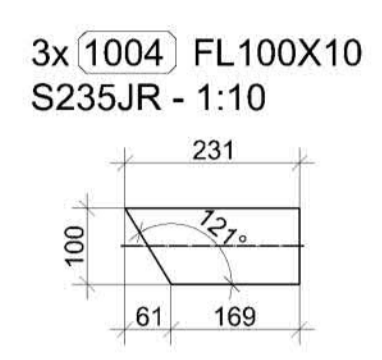
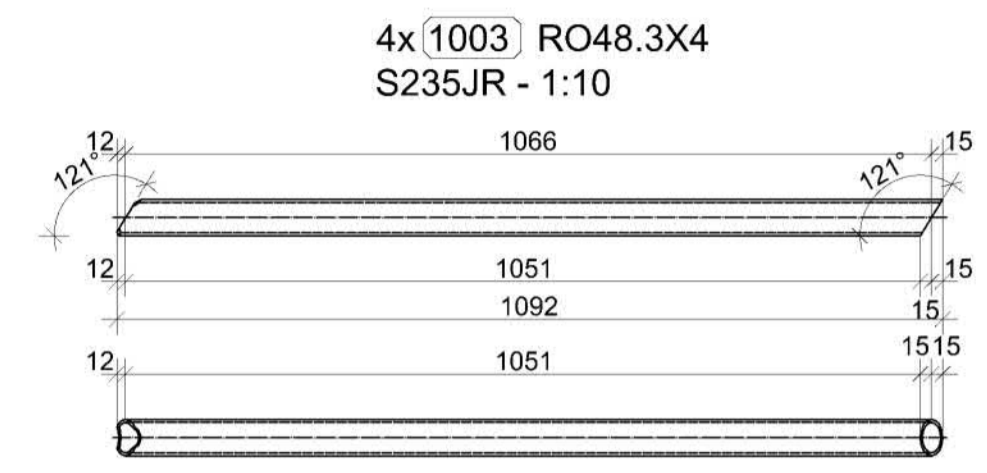
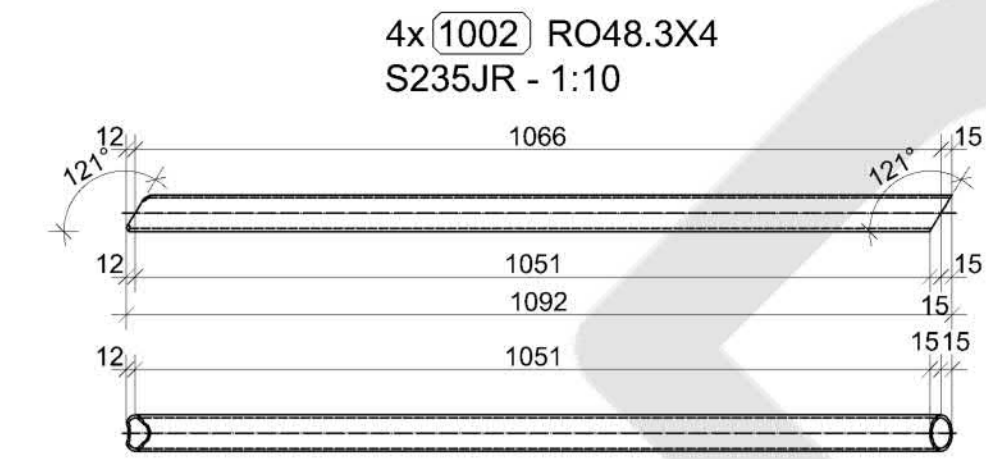
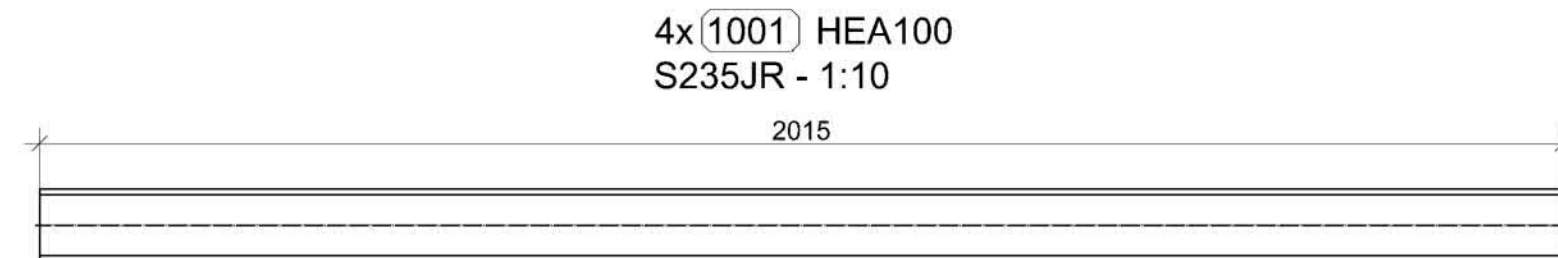
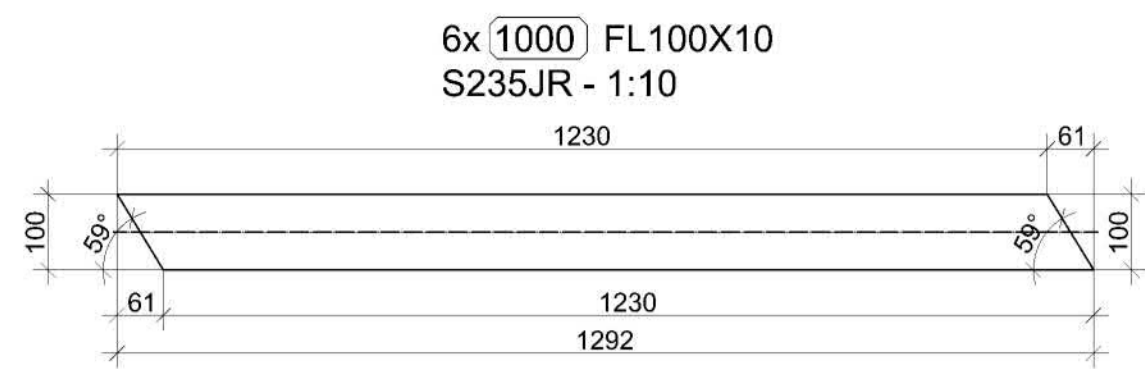

PRESECI

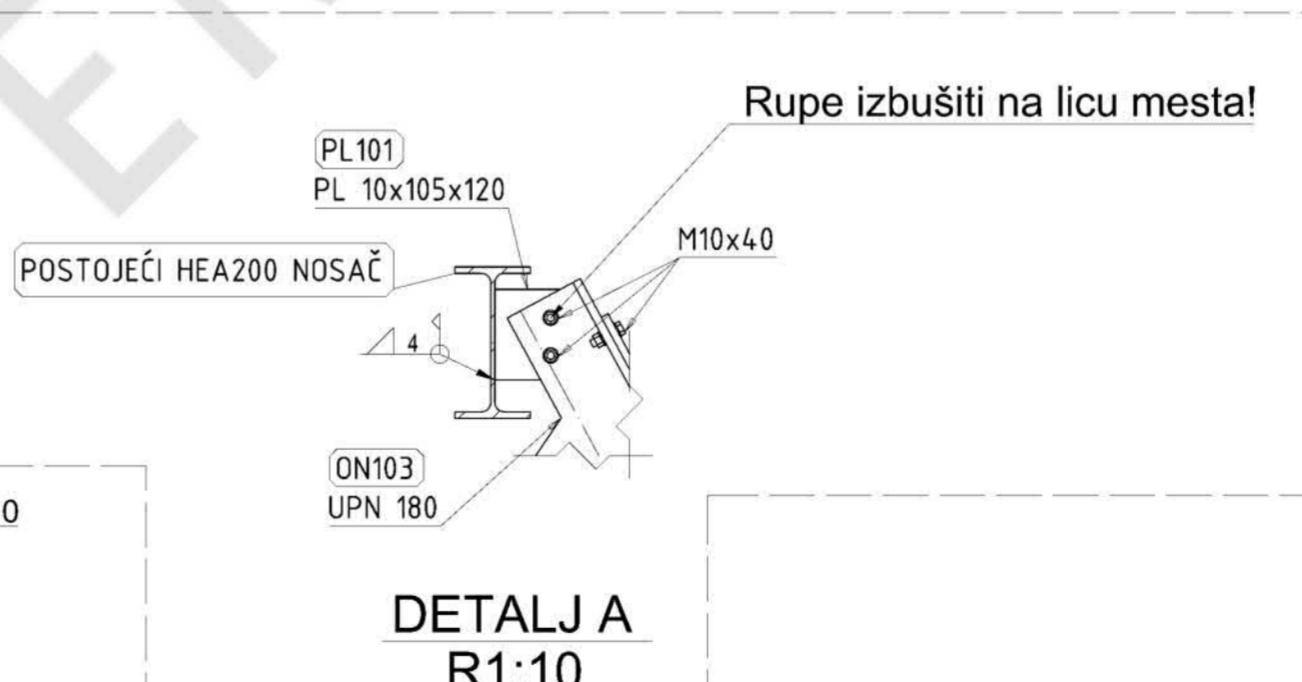
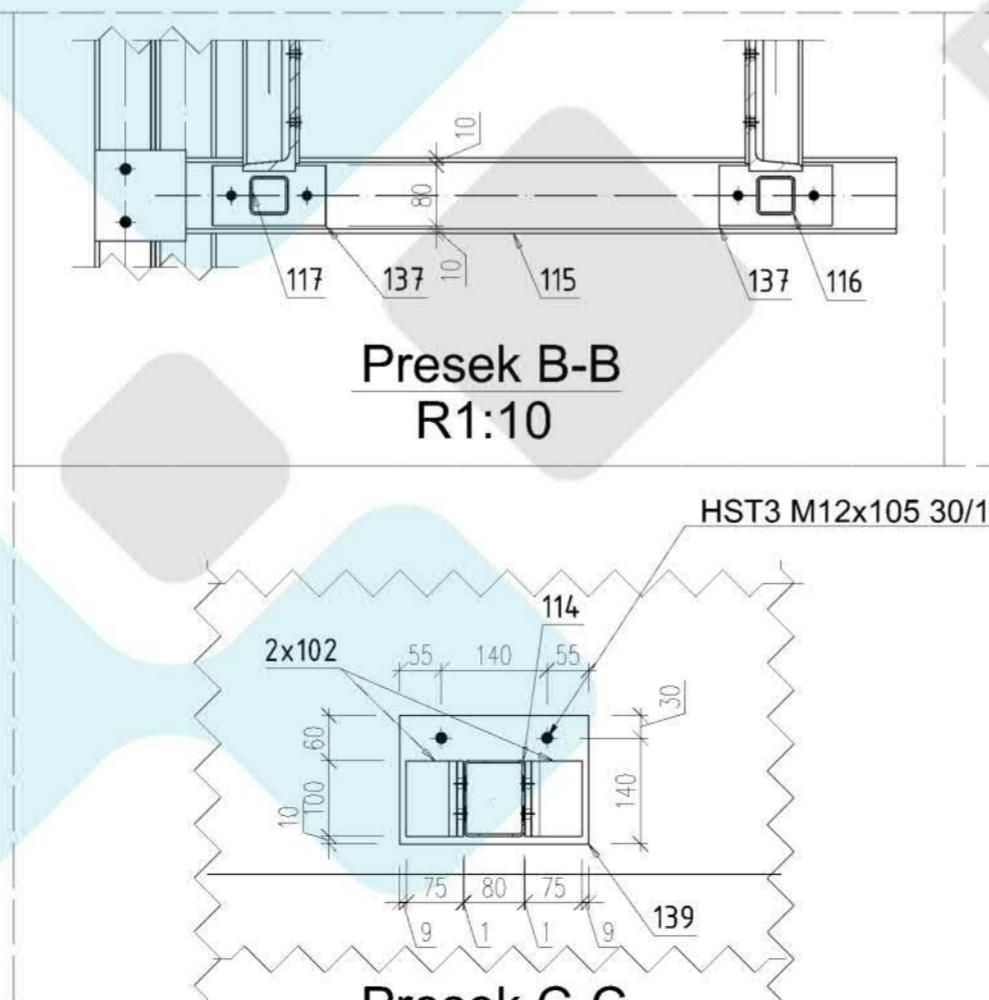
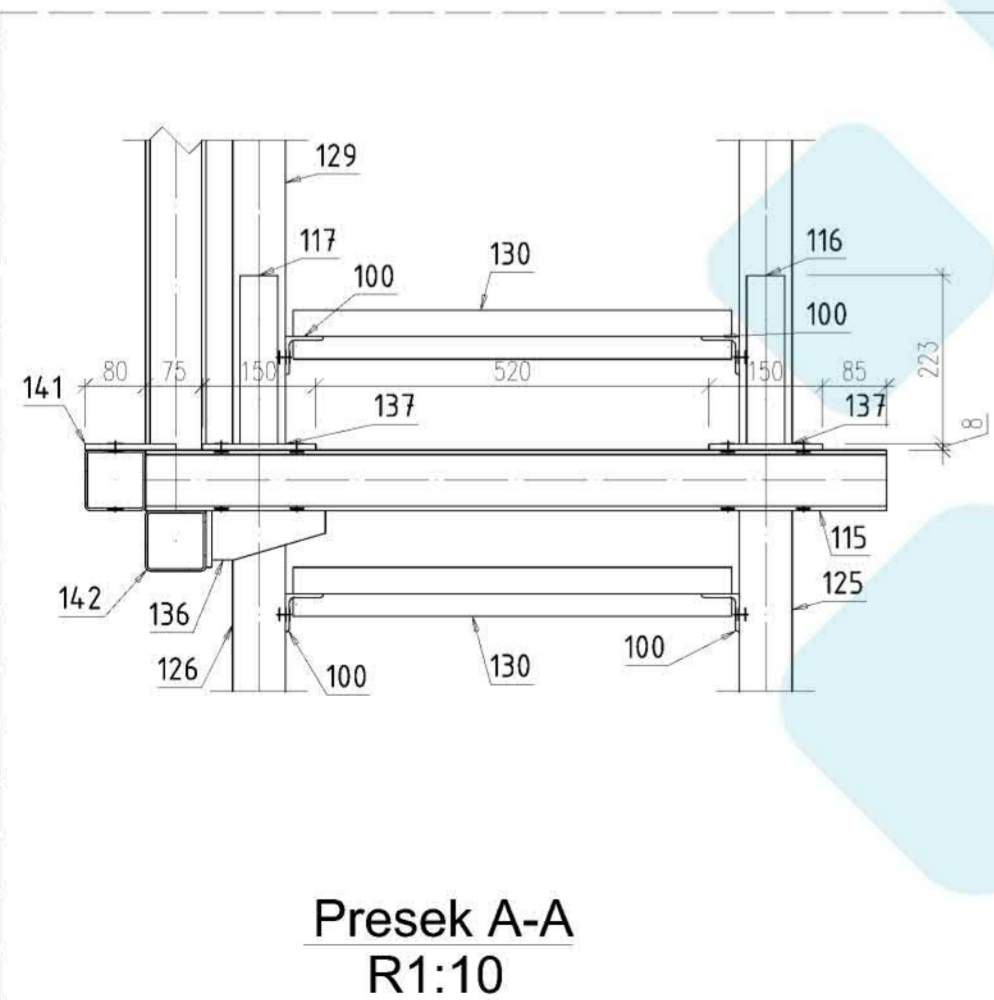
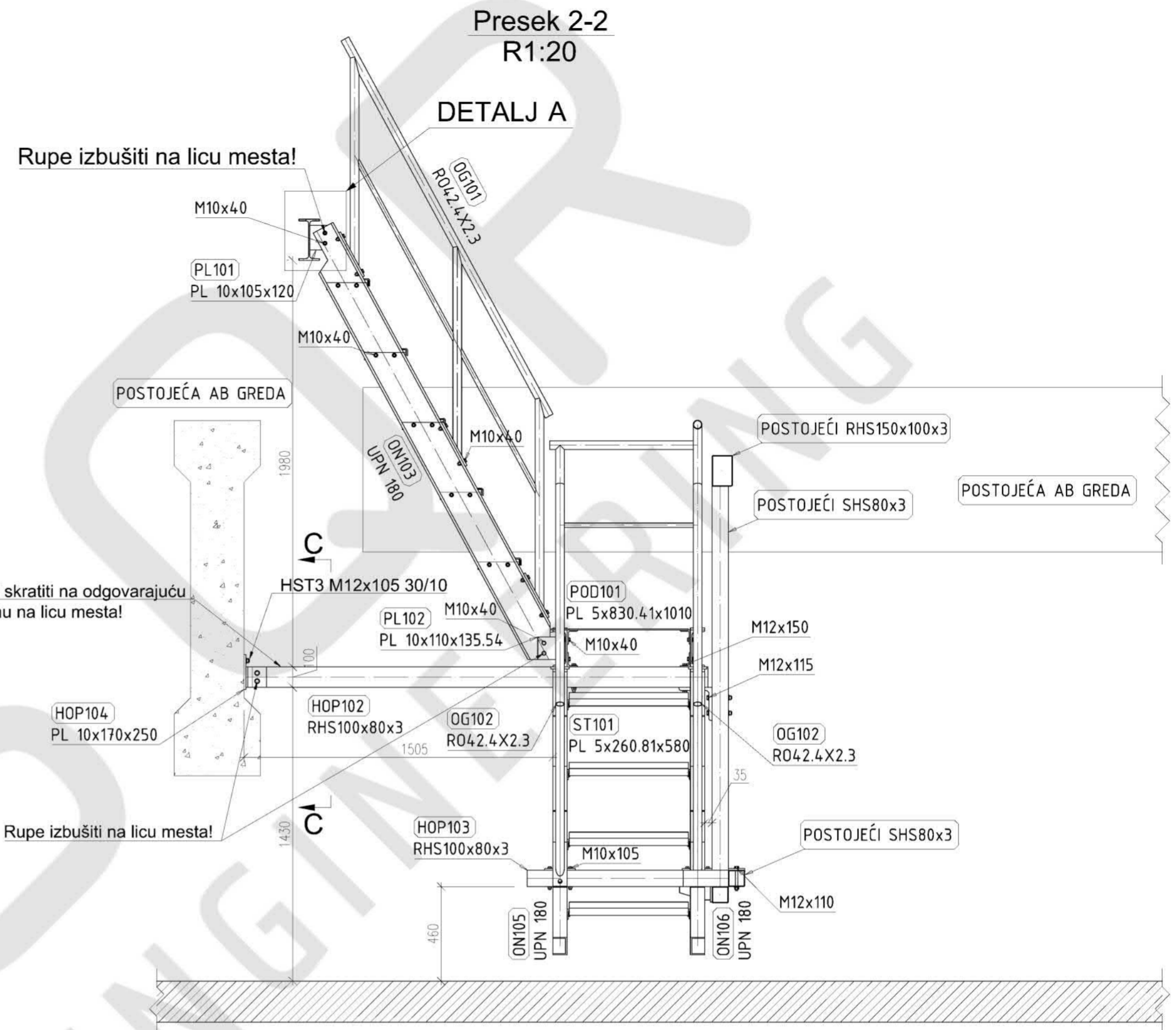
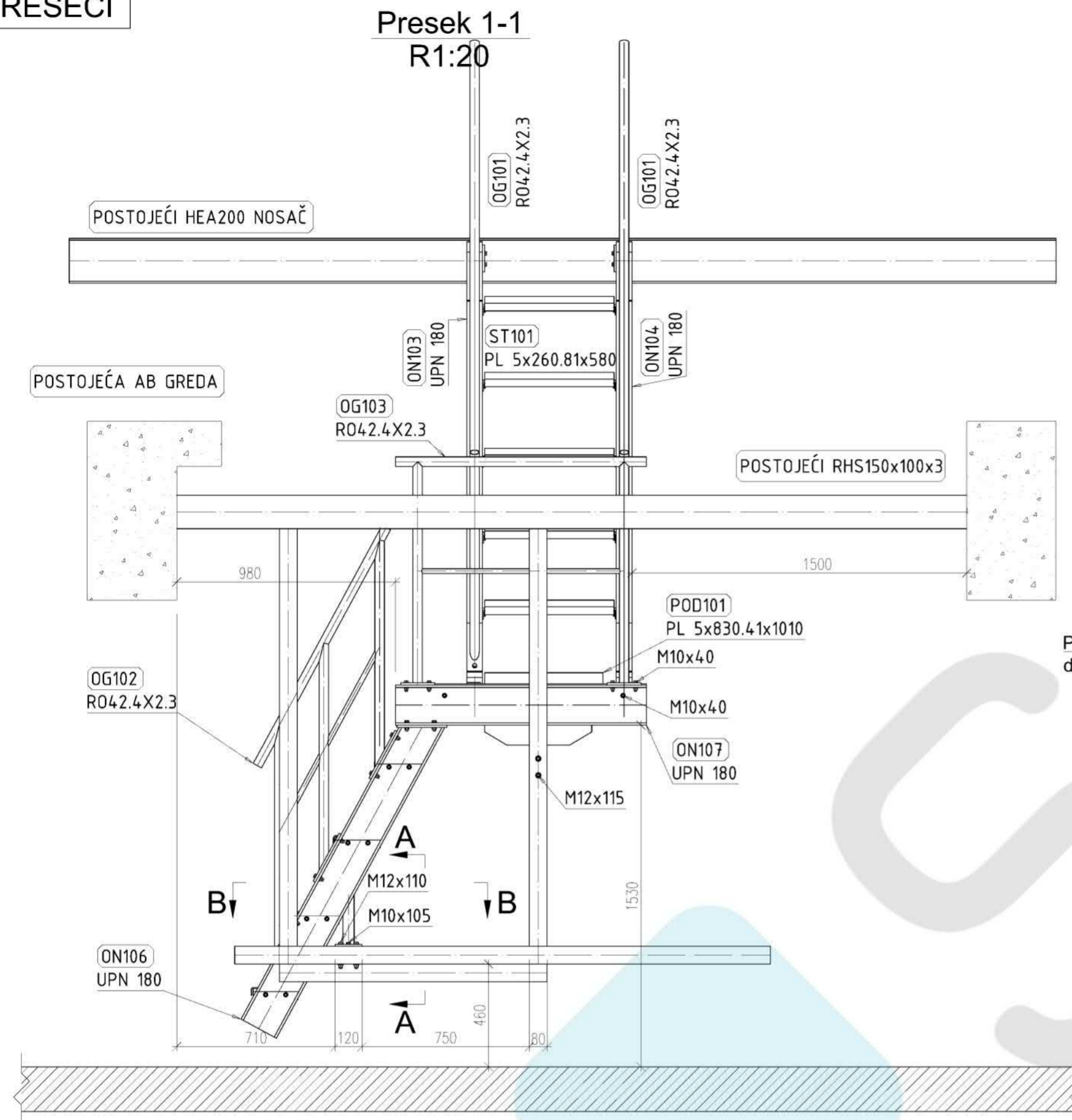

Mark	Quantity	Description	Length	Grade	Part weight	Total weight
OG101	2	R04.2.4X2.3				
108	2	R04.2.4X2.3	2089	S235	4.75	9.5
101	6	R04.2.4X2.3	1018	S235	2.32	13.89
104	2	R021.3X3.2	1000	S235	1.43	2.86
129	6	PL 10x70x243.98	244	S235	1.34	8.04
105	2	R021.3X3.2	790	S235	1.13	2.26
One assembly weight:					18.28	36.56
Combined Total						36.56

2x **OG101** R04.2.4X2.3 - 1:10

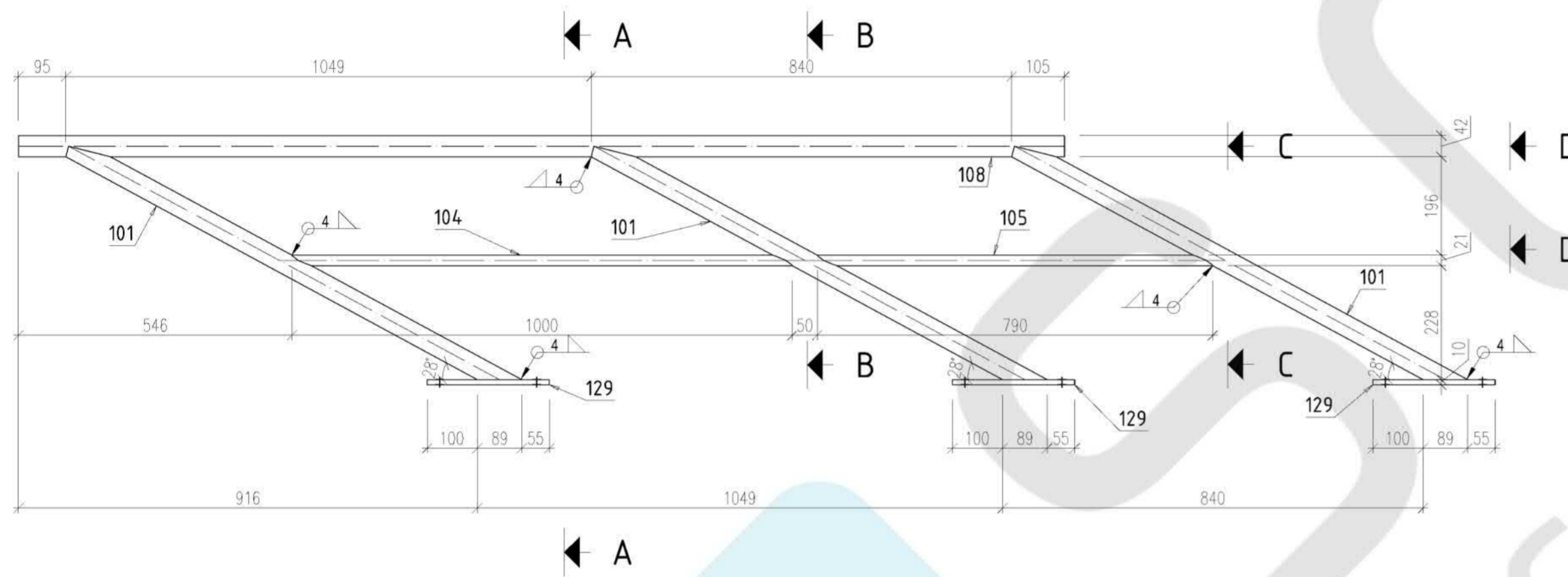

12x **101** R04.2.4X2.3
S235 - 1:10

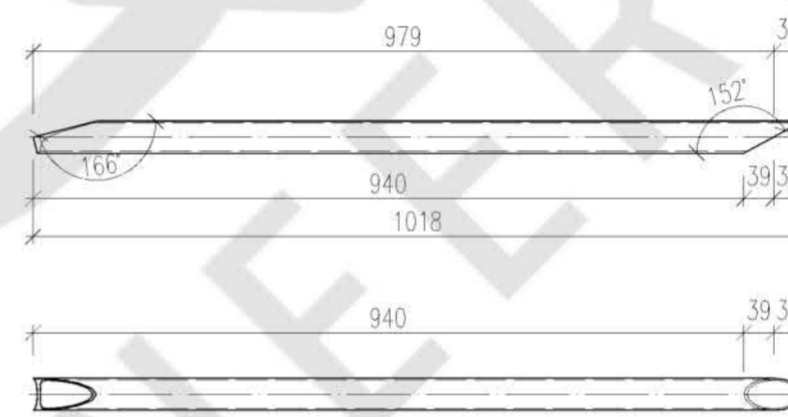

2x **104** R021.3X3.2
S235 - 1:10

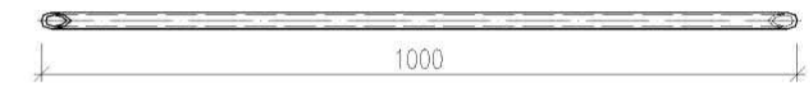

2x **105** R021.3X3.2
S235 - 1:10



2x **108** R04.2.4X2.3
S235 - 1:10



12x **129** PL 10x70x243.98
S235 - 1:10

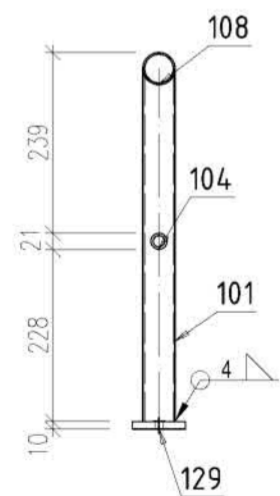
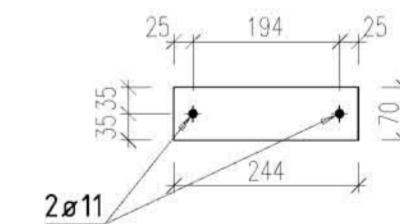

A - A

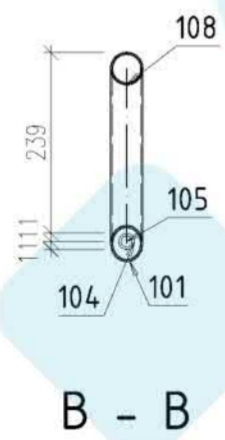

B - B

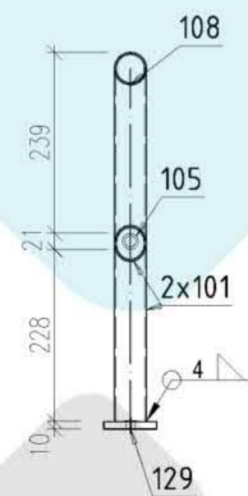

C - C

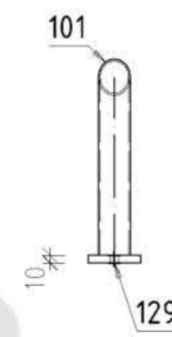

D - D

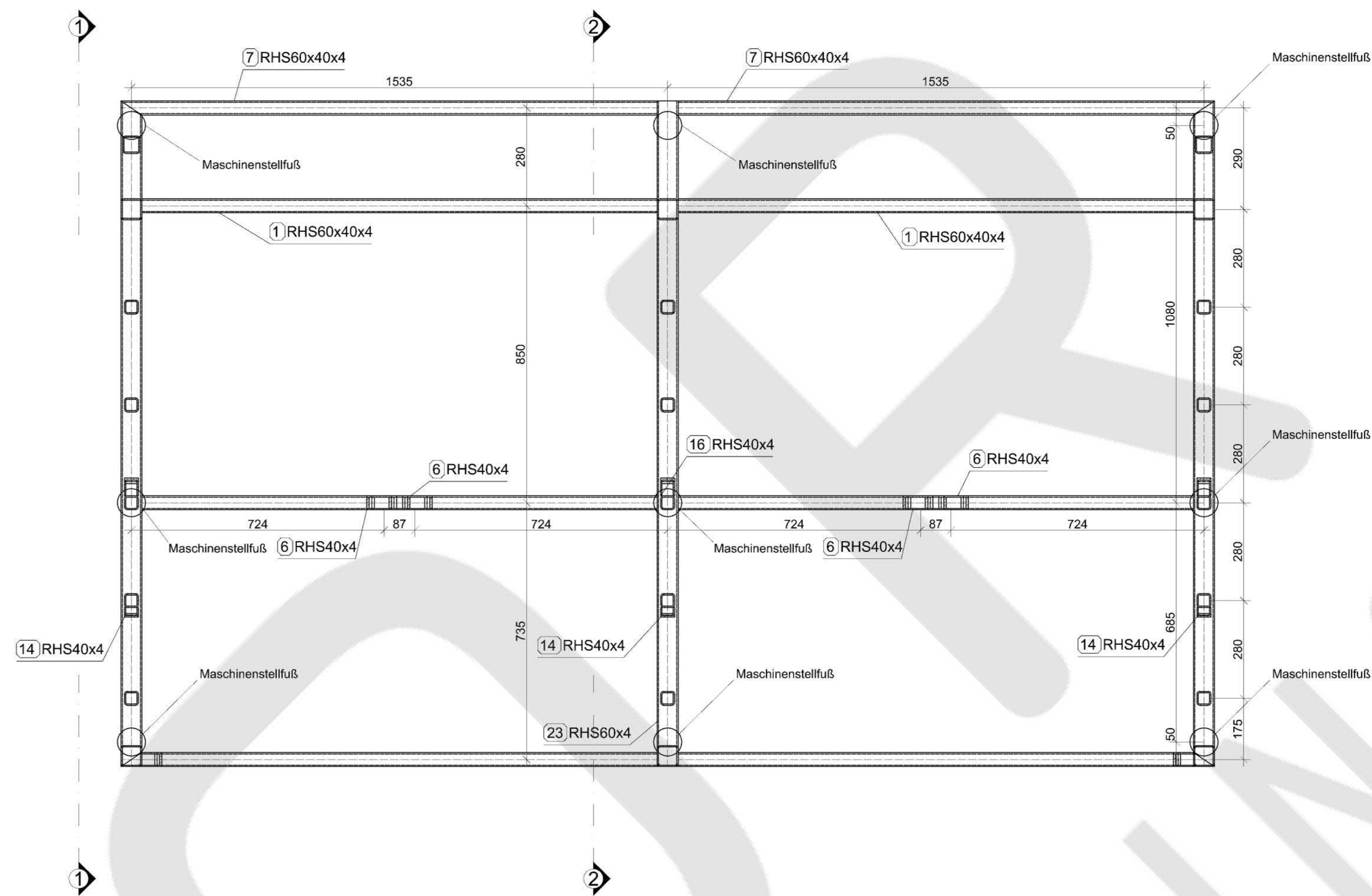
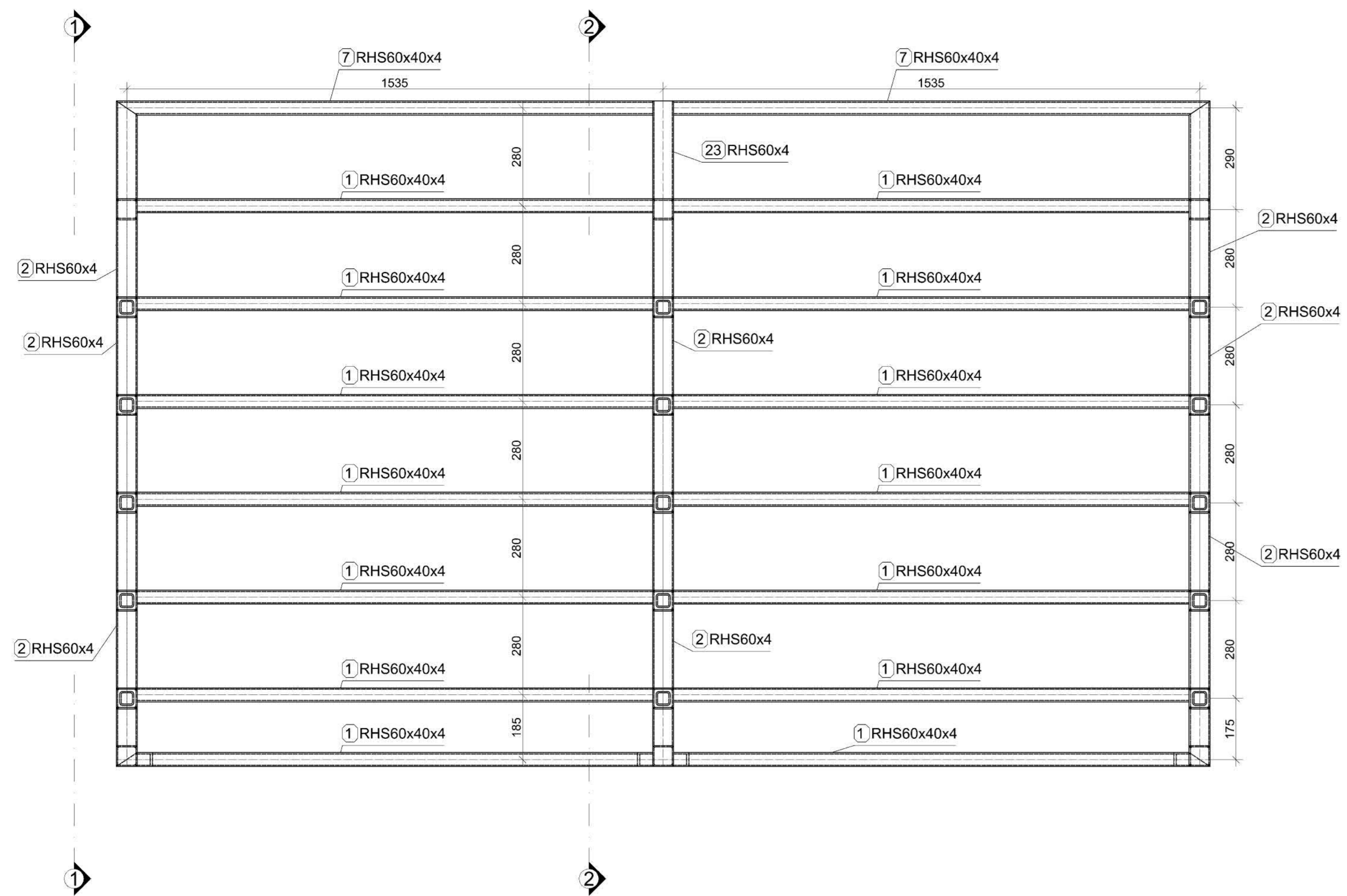

Schnitt 1-1

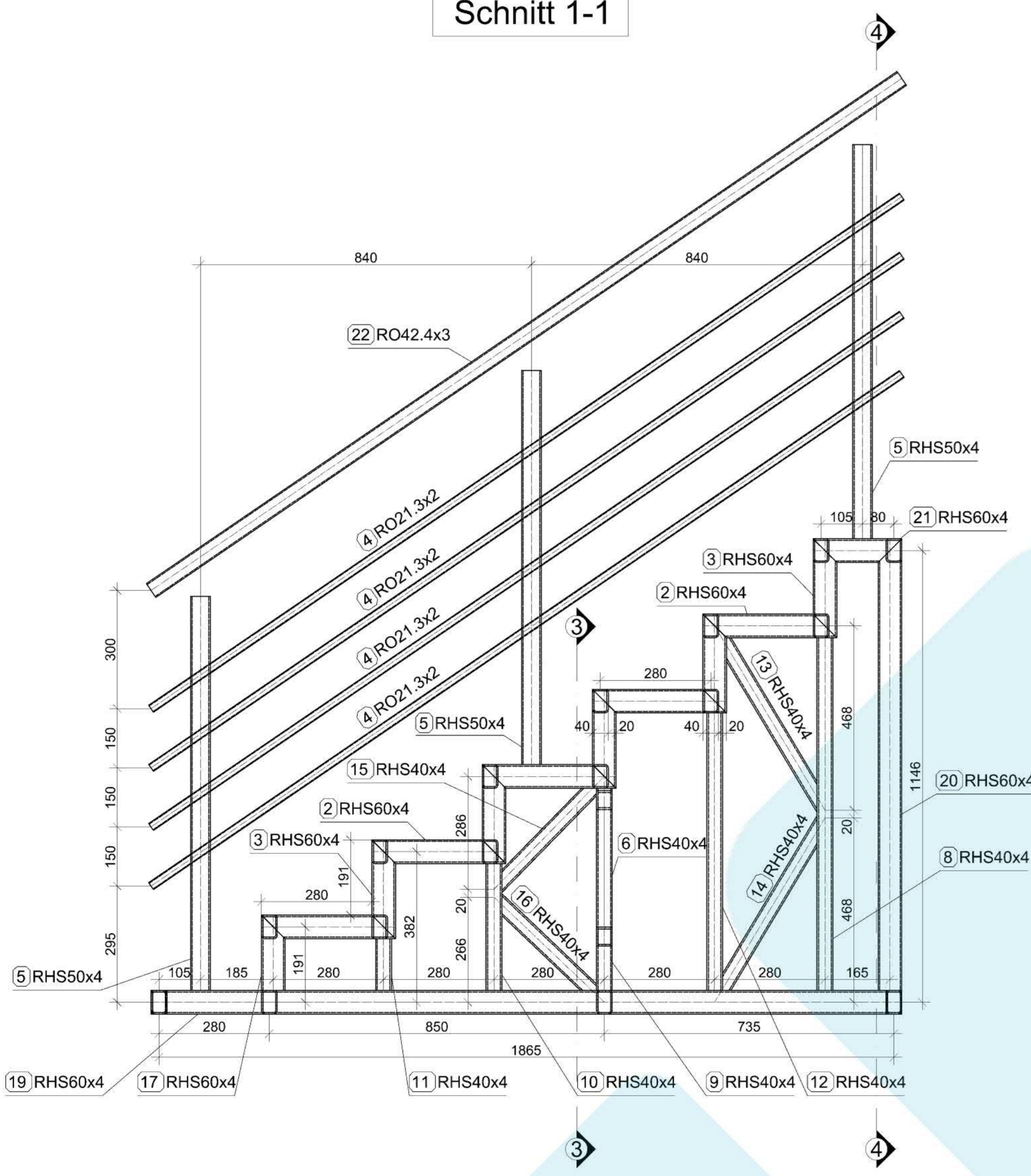

Schnitt 2-2

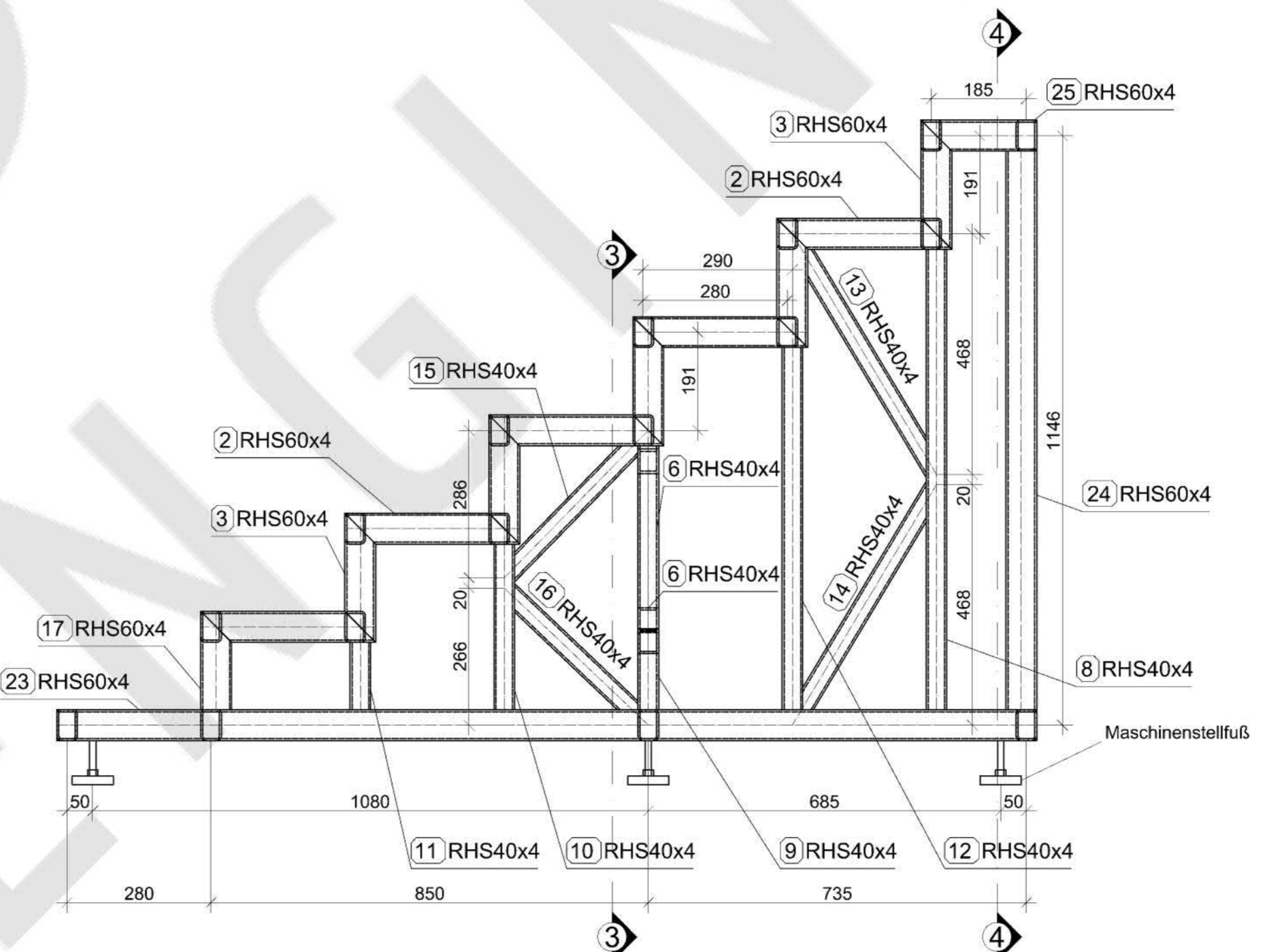

Schnitt 3-3

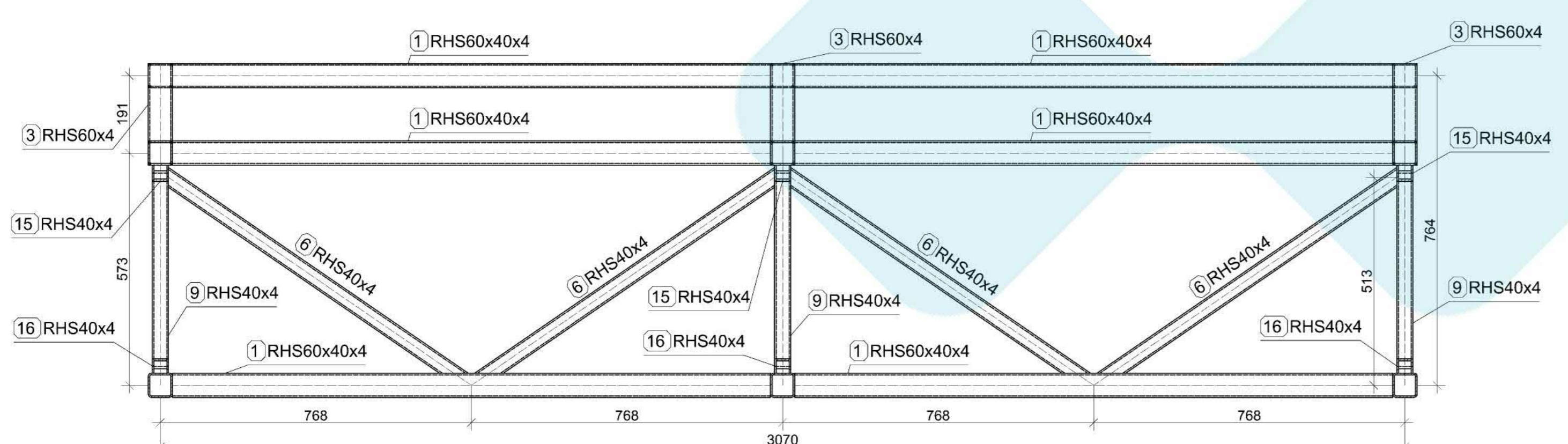

Schnitt 4-4

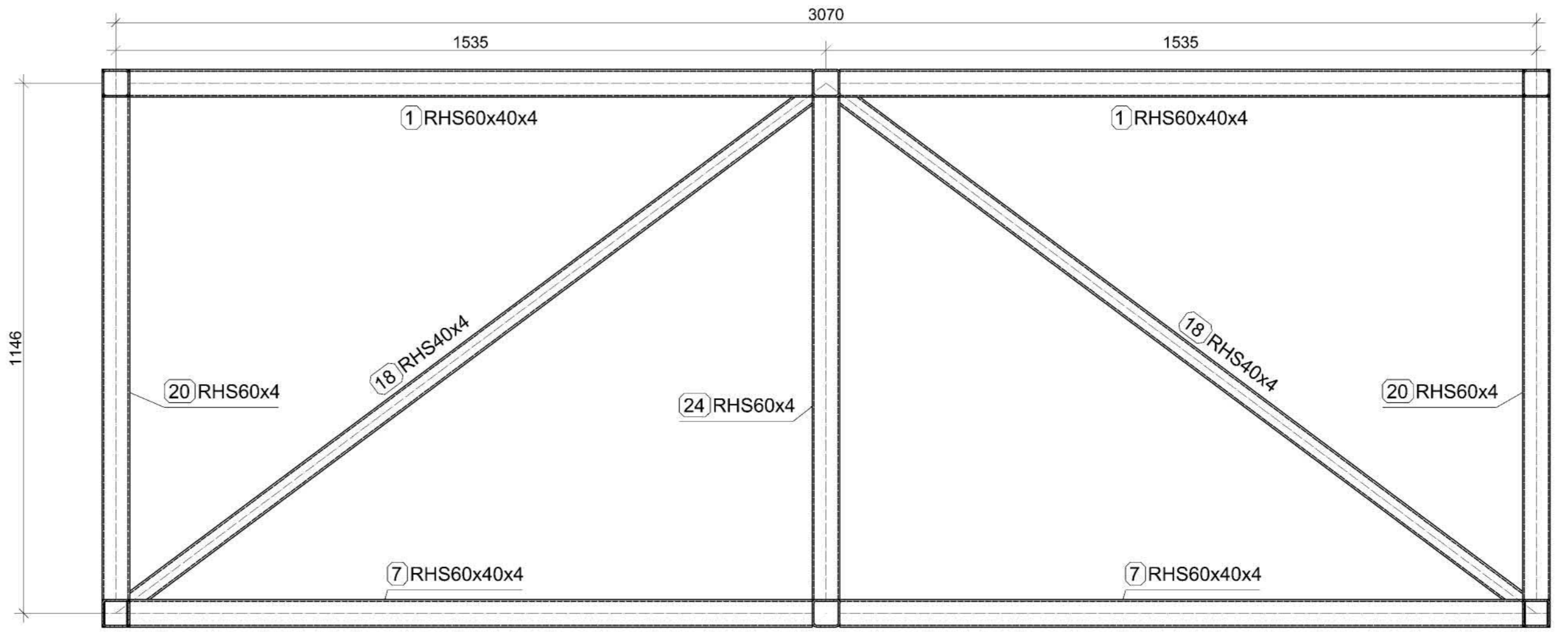

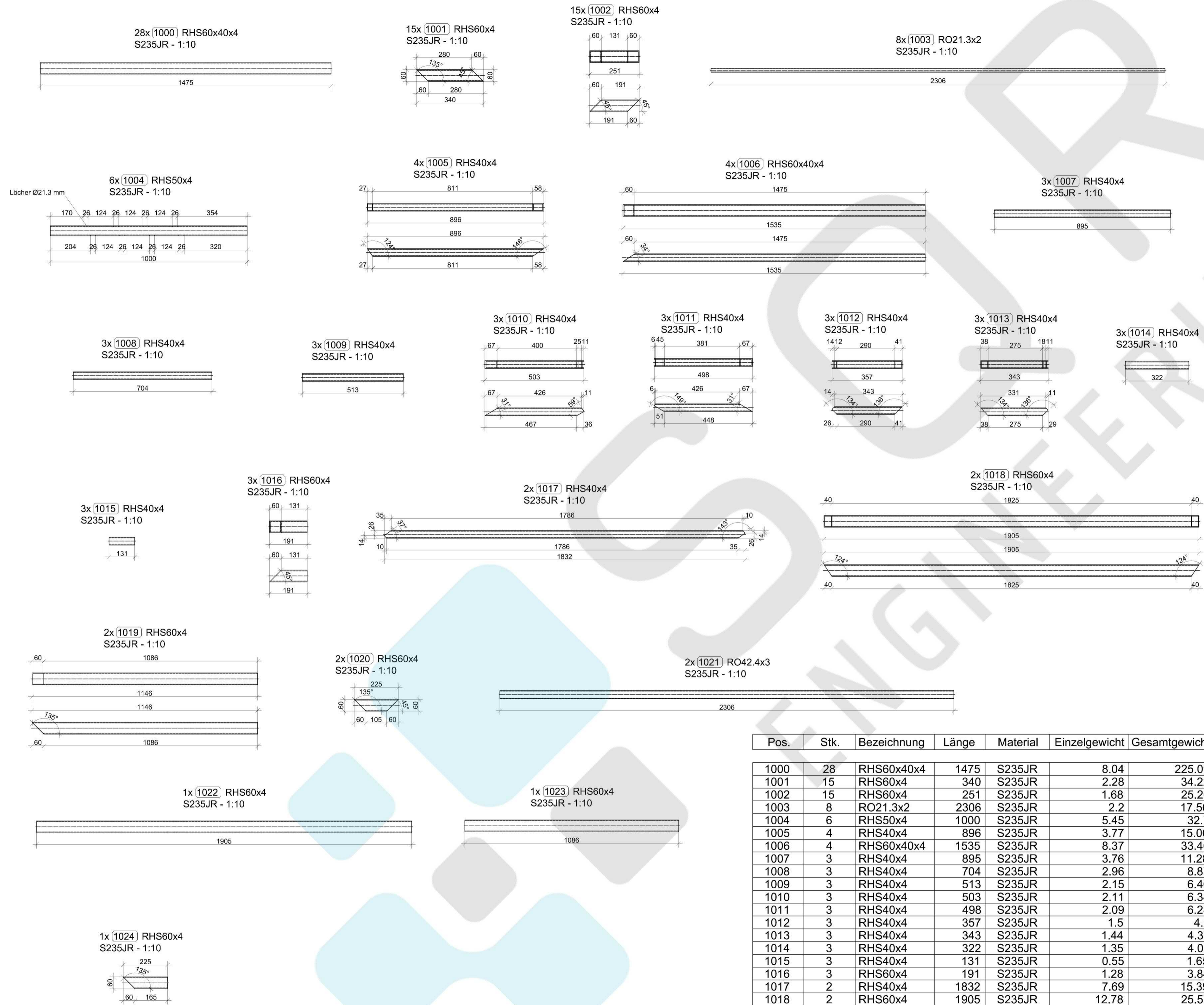

Pos.	Stk.	Bezeichnung	Länge	Material	Einzelgewicht	Gesamtgewicht
1000	28	RHS60x40x4	1475	S235JR	8.04	225.09
1001	15	RHS60x4	340	S235JR	2.28	34.22
1002	15	RHS60x4	251	S235JR	1.68	25.26
1003	8	RO21.3x2	2306	S235JR	2.2	17.56
1004	6	RHS50x4	1000	S235JR	5.45	32.7
1005	4	RHS40x4	896	S235JR	3.77	15.06
1006	4	RHS60x40x4	1535	S235JR	8.37	33.46
1007	3	RHS40x4	895	S235JR	3.76	11.28
1008	3	RHS40x4	704	S235JR	2.96	8.87
1009	3	RHS40x4	513	S235JR	2.15	6.46
1010	3	RHS40x4	503	S235JR	2.11	6.34
1011	3	RHS40x4	498	S235JR	2.09	6.28
1012	3	RHS40x4	357	S235JR	1.5	4.5
1013	3	RHS40x4	343	S235JR	1.44	4.32
1014	3	RHS40x4	322	S235JR	1.35	4.06
1015	3	RHS40x4	131	S235JR	0.55	1.65
1016	3	RHS60x4	191	S235JR	1.28	3.84
1017	2	RHS40x4	1832	S235JR	7.69	15.39
1018	2	RHS60x4	1905	S235JR	12.78	25.57
1019	2	RHS60x4	1146	S235JR	7.69	15.38
1020	2	RHS60x4	225	S235JR	1.51	3.02
1021	2	RO42.4x3	2306	S235JR	6.72	13.44
1022	1	RHS60x4	1905	S235JR	12.78	12.78
1023	1	RHS60x4	1086	S235JR	7.29	7.29
1024	1	RHS60x4	225	S235JR	1.51	1.51
		Gesamt				535.33

TREPPE 1

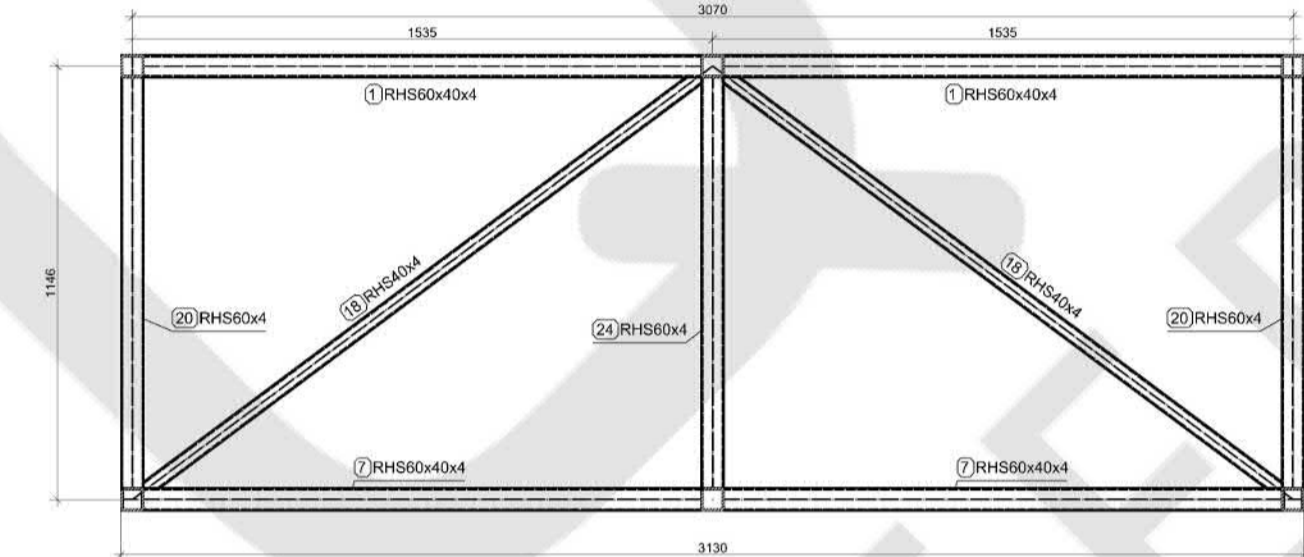
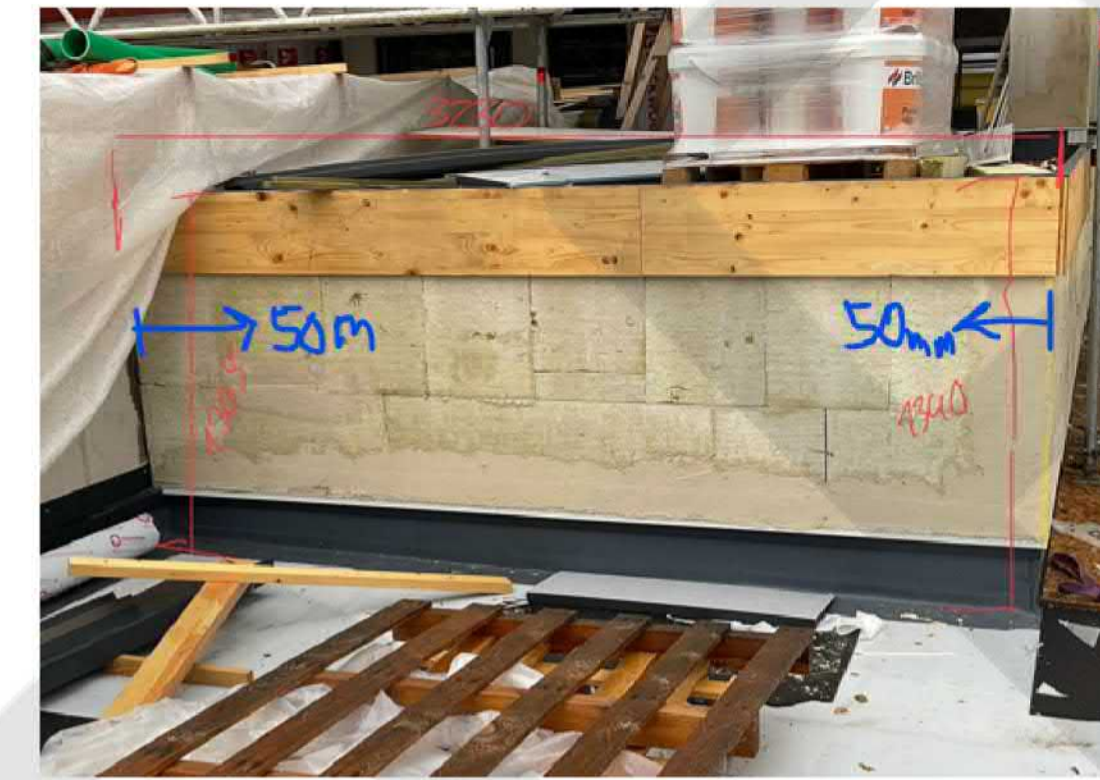
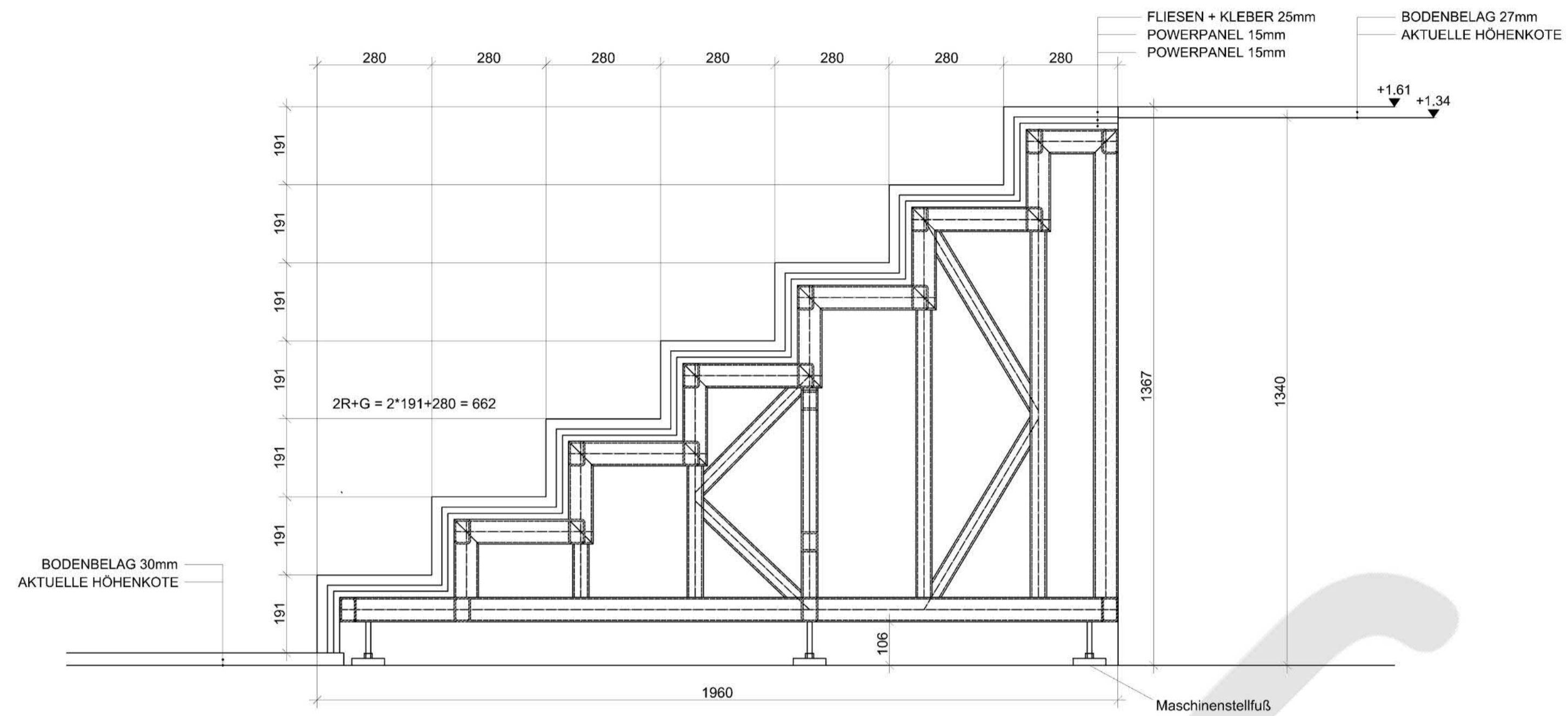

TREPPE 2

